

ANARUMO INSPECTIONS INC

# HOME MAINTENANCE MANUAL

4th Edition



**ANARUMO INSPECTIONS**  
— I N C. —

[www.anarumo.com](http://www.anarumo.com)

# ANARUMO INSPECTIONS INC HOME MAINTENANCE MANUAL



Fourth Edition

**Anarumo Inspections Inc**

[www.anarumo.com](http://www.anarumo.com)

(310) 925-6664

## ***Welcome to Your Home Maintenance Manual!***

Realizing that your home is probably one of the biggest investments that you will ever make, this manual was developed to help you take care of your investment. Of course no house lasts forever, but proper regular maintenance will increase the life span of your home and help to prevent costly repairs that could have been avoided. Also, by keeping your home well maintained, you will be doing your part to preserve the overall quality of life in your neighborhood and community.

This manual is designed to serve as an at-home reference tool. Different components of your home are briefly described and check lists for almost every topic are included. The checklists are designed to help manual you through maintenance checks and through decisions about whether or not a certain repair requires professional attention.

Only suggestions for the most common types of houses are given, such as ranch, bungalow, split-level, condominiums, townhomes and other common homes. Because this manual has information about various housing types and systems, some information will not apply to your particular home. For example, this manual expands upon *many* types of roofing available, such as asphalt, wood shingles, slate/clay tile, and roll roofing, and you will need to select that which is relevant to your home.

Definitions of technical terms used in this manual are included in the **Glossary** at the end of the manual.

## Top 15 Tools Every Homeowner Should Own

Now that you have your new home, you should be ready to do some minor repairs and maintenance. To do so, you should own a basic set of tools. The following items are essential tools but this list is by no means exhaustive. While we recommend getting familiar with basic tools and minor repairs, technically exhaustive or potentially dangerous repairs should be left to the professionals.

### 1. Plunger

A clogged sink or toilet is one of the most disturbing problems that you will face. With a plunger on hand, however, you can usually remedy these troubling plumbing issues relatively quickly. It is best to have two plungers -- one for the sink and one for the toilet.



### 2. Combination Wrench Set

One end of a combination wrench set is open and the other end is a closed loop. Nuts and bolts are manufactured in standard and metric sizes and because both varieties are widely used, so you'll need both sets of wrenches. For the most control and leverage, always pull the wrench toward you, instead of pushing on it. Also, avoid over-tightening.



### 3. Slip-Joint Pliers

Use slip-joint pliers to grab hold of a nail, a nut, a bolt, and much more. These types of pliers are versatile because of the jaws, which feature both flat and curved areas for gripping many types of objects. There is also a built-in slip-joint, which allows the user to quickly adjust the jaw size to suit most tasks.



### 4. Adjustable Wrench

Adjustable wrenches are somewhat awkward to use and can damage a bolt or nut if they are not handled properly. However, adjustable wrenches are ideal for situations where you need two wrenches of the same size. Screw the jaws all the way closed to avoid damaging the bolt or nut.



### 5. Caulking Gun

Caulking is the process of sealing up cracks and gaps in various structures and certain types of piping. Caulking can provide noise mitigation and thermal insulation, and control water penetration. Caulk should be applied only to areas that are clean and dry.



## **6. Flashlight**

None of the tools in this list is of any use if you cannot visually inspect the situation. The problem, and solution, are apparent only with a good flashlight. A traditional two-battery flashlight is usually sufficient, as larger flashlights may be too unwieldy.

## **7. Tape Measure**

Measuring house projects requires a tape measure, not a ruler or a yardstick. Tape measures come in many lengths, although 25 feet is best. Measure everything at least twice to ensure accuracy.

## **8. Hacksaw**

These are great for cutting metal objects such as pipes, bolts and brackets. Hacksaws look thin and flimsy, but they'll easily cut through even the hardest of metals. Blades are replaceable, so focus your purchase on a quality hacksaw frame.

## **9. Torpedo Level**

Only a level can be used to determine if something, such as a shelf, appliance or picture, is correctly oriented. The torpedo-style level is unique because it not only shows when an object is perfectly horizontal or vertical, but it also has a gauge that shows when an object is at a 45-degree angle. The bubble in viewfinder must be exactly in the middle, not merely close.



## **10. Safety Glasses / Goggles**

For all tasks involving a hammer or a power tool, you should always wear safety glasses or goggles. They should also be worn while you mix chemicals.

### **11. Claw Hammer**

A good hammer is one of the most important tools you can own. Use it to drive and remove nails, to pry wood loose from the house, and in combination with other tools. They come in a variety of sizes, although a 16-ounce hammer is the best all-purpose choice.



### **12. Screwdriver Set**

It is best to have four screwdrivers: a small and large version of both a flat-head and a Phillips-head screwdriver. Electrical screwdrivers are sometimes convenient, but they're no substitute. Manual screwdrivers can reach into more places and they are less likely to damage the screw.

### **13. Wire Cutters**

Wire cutters are pliers designed to cut wires and small nails. The "side-cutting" (unlike the stronger "end-cutting" style) style is handy, but not strong enough to cut small nails.

### **14. Respirator / Safety Mask**

While paints and other coatings have become less toxic (and lead-free) over time, most still contain dangerous chemicals, which is why you should wear a mask to avoid accidentally getting them in your lungs. A mask should also be worn when working in dusty or dirty environments. Disposable masks usually come in packs of 10 and should be thrown away after use. Full and half-face respirators can be used to prevent the inhalation of very fine particles that ordinary face masks will not stop.

### **15. Duct Tape**

This tape is extremely strong and adaptable. Originally, it was widely used to make temporary repairs to many types of military equipment. Today, it's one of the key items specified for home emergency kits because it is water-resistant and extremely sticky.

## Part 1: Outside the Home



*This section gives a general overview on maintenance activities for the exterior, which provides protection for your home's framework and interior features. Maintaining the roof, wall, foundation and other components in good repair is critical.*



# ROOFS

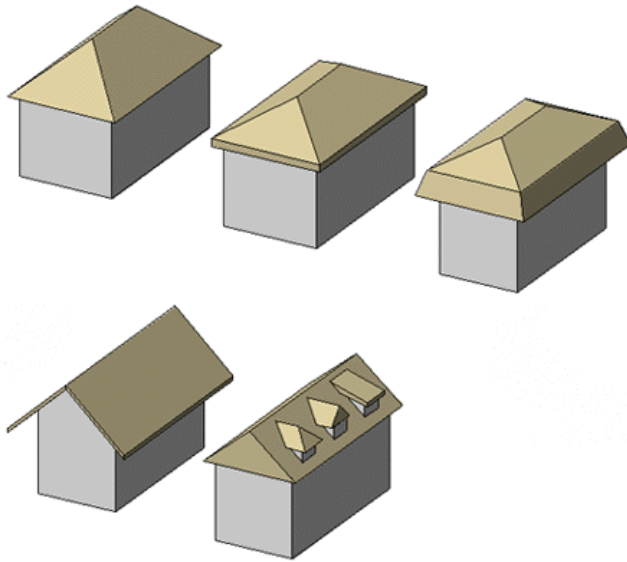

This manual begins by discussing the roof because a weather-tight roof is basic to the preservation of your home, no matter how old or new it is. The roof sheds rain, shades the sun and serves as a general buffer from the weather.

During different architectural periods in the history of the United States, a variety of roofing materials were used, such as clay tiles, slate, copper, tin and asbestos. Common roofing materials are listed below. Each variety of roof has different features and expected life spans. Being aware of the general facts concerning your roof will help you to budget for future replacement or repairs.

**Table 1: Common Roofing Materials**

Material	Maintenance	Life Span
Asphalt Shingles	Little at first, but over the years some shingles begin to curl, crack and lose their surface coatings. Not difficult to repair or replace.	15 to 30 years under temperate weather conditions. Better-quality asphalt shingles carry 25-year guarantees. Life span is also affected by the color of the shingles. Light colored roofs tend to last longer than dark colored ones.
Wood Shingles and Shakes	Unsealed types sometimes tend to rot, warp, split and soon weather to a soft gray. Not difficult to repair or replace.	20 years or more for shingles; up to 35 years for shakes if maintained well.
Slate, Clay Tiles	An occasional cracked or chipped tile may need repair.	The life span of your house, provided you make repairs before the underlying layer of sheathing is damaged.
Roll Roofing	Lightweight, single-layer installations fail frequently, but repairs are very easy.	From 5 to 15 years. With short-term warranties, ask if the company will come back for patching.

Tin Roofing	May need periodic painting, especially if it comes in contact with any other metal.	Tin roofs are very durable and last for many decades.
-------------	---	---

The life span given for each type of roof in Table 1 is dependent upon regular maintenance and checks. Each roof, regardless of the materials used, has features which must be continually maintained and checked. If you have questions, call a qualified professional.

**Checklist for the Roof:**

**RIDGE CAPS.** These shingles, located on the crest of the roof, often fail first. Look for cracks and wind damage. A leak here could show up almost anywhere in the house.

**FLASHING.** *This is by far the most common location for water intrusion into your house.* Flashing is metal strips which provide the transition between two different kinds of surfaces and binds them together, offering additional protection against leakage. It is located in valleys or around protrusions on the roof such as plumbing vent pipes or chimneys. Check all flashings. They should be tight, rust-free, and sealed with roofing cement, which can also be used to repair minor leaks around flashing.

**VALLEYS.** Valleys, where two slopes meet to help direct runoff into gutters, are another place where deterioration soon causes problems. If there is flashing in the valleys, make sure that it is tight fitting and without holes or rust.

**ROOF AND SOFFIT VENTS.** Be sure that your attic is properly ventilated. Consult a manual or a professional to determine the proper vent system for your home.

**SHINGLES.** Check for loose, curled-up, or missing shingles which will admit moisture that could weaken the underlying sheathing and harm walls and ceilings below. If branches hit your roof during storms or high winds, they need to be trimmed back in order to avoid damaging the shingles.

**GRANULES IN THE GUTTER.** A large accumulation of granules in the gutter means that your roof is losing its coating. Your roof may need to be replaced soon. Consult with a professional.

**LEAKS.** Check for water stains on framing, sheathing, and insulation in the attic and on the roof. Leaks usually originate higher up than the area where they first appear.

**NOTE:** *Do not go up on your roof when it is raining, it will be slippery. Be careful around wiring and the electrical service; contact the electrical company for advice if you need to work close to the electrical service. Also, use extra care when placing and climbing ladders.*

**GUTTERS.** Gutters are usually made of metal and run below and along the edge of your roof. Gutters and downspouts help divert water away from your home, thus preventing premature rotting or damage to the roof, walls and foundation caused by water. Make sure that gutters are attached securely to the roof and walls. If they are not properly attached, damage to your siding, interior walls or foundation can result. Gutters and downspouts must be cleaned frequently, particularly in the fall if you have large trees close to your home. Clogged gutters can result in damp walls or foundation, or cause ice dams during the winter.

**Checklist for Gutters:**

**DEBRIS.** Mud and rotting leaves not only clog up gutters and downspouts, they also hold moisture that causes rust, rot, and corrosion. Hose your gutters clean. Begin at the high end of each gutter or in the middle of gutters if they have spouts at both ends. Sometimes you can blast out a spout blockage with hose pressure. If not, break up the jam with a broom handle or a plumber's snake.

**RUST/CORROSION.** Inspect the inside of your gutters after cleaning them. If any part is beginning to rust, scrape and wire-brush them, then apply a thin coat of roofing cement. Small holes can be fixed by pressing a thin sheet of metal into roofing cement. Plastic roofing cement is available at your local hardware or building supply store.

**SLOPE.** All gutters must slope slightly toward their downspouts. Run water through the gutter in order to determine if the gutters are properly sloped for effective water drainage. Many problems are caused by standing water due to flat or sagging gutters.

**RUN-OFF EXTENSIONS.** Make sure downspout extensions are directing water away from the foundation. Runoff extensions should extend at least four feet away from your house. Also make sure that water is not eroding sections of your yard.

**NOTE:** *If your roof or gutters fails to pass any component of this check-up, check with your local library "houses - maintenance and repair" section for repair information and/or call a professional.*

# CHIMNEY & FIREPLACE

Chimneys not only channel smoke out of your fireplace, they also serve to contain toxic gases, heat and flames. Heat and water tend to cause chimneys to deteriorate. For example, water driven into mortar joints by the wind and acid created by some woods when burned both lead to the erosion of mortar.

Inspections of the outside of your chimney should be done annually, checking every surface you can see, including any in-the-attic portions, looking for cracks and deteriorated mortar. Chimneys also need to be cleaned at least once a year. Depending on how often you use it and the kind of wood you burn, they may need to be cleaned more frequently. Cleaning helps prevent poisonous fumes from entering the house or a fire in the chimney wall itself. It's best to hire a chimney sweep company to clean your chimney.

## Checklist for Chimneys:

**JOINTS AND FLUE.** Wind driven rain often erodes mortar joints. These will need to be tuck-pointed by a professional. If not repaired, moisture can seep through, causing damage to walls and ceilings. Mortar should be packed around the flue.

**HOT SPOTS.** Every once in a while test for chimney hot spots by feeling reachable areas with your hand. If an area on the chimney is unusually hot, this may need your immediate attention. Hot spots may mean a broken flue, a fire hazard that a mason should attend to before you use the fireplace again.

## CROWN

One of the most common defects that we find during a home inspection is a cracked crown (see photo above) and a missing chimney flue cap. A cracked crown can allow water to seep inside the chimney, between the brick and the flue liner. Over time, this can deteriorate the mortar between the bricks and the liner causing them to come loose. This can pose a structural concern to the chimney and a fire hazard to the house and occupants.

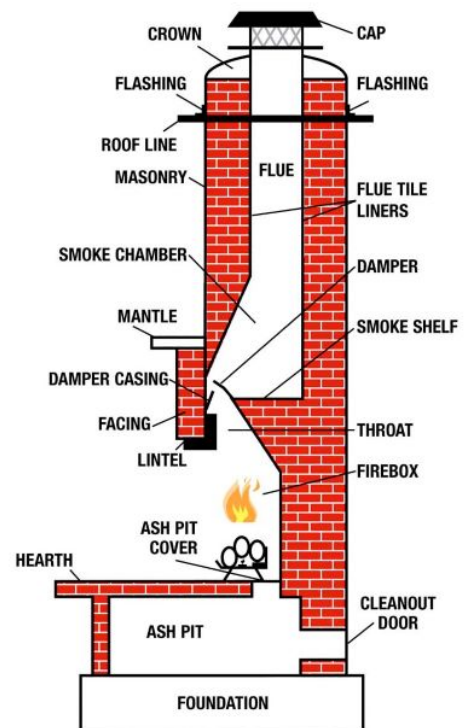

### **RAIN CAP/SPARK ARRESTOR.**

Like a damaged crown, the lack of a chimney cap/spark arrestor can also allow for water to cascade down the chimney flue when it rains, and over time deteriorate the mortar between the bricks and chimney liner tiles. However, the lack of a spark arrestor can allow for live embers from the fireplace to escape. In certain areas, embers from fireplaces can pose a significant fire hazard not only to the house but to surrounding neighborhoods. In both cases, the damage to the chimney can also require costly repairs. An inexpensive cap/spark arrestor, as in the photo, can prevent both concerns.



### **FLASHINGS**

Chimney flashing is the sheet metal that connects the roof surface to the chimney and prevents roof leaks into the house. Without getting too technical here, the flashing is made up of two parts. The step flashing is tucked under the shingles, and the counter flashing is attached to the chimney and overlaps the step flashing. The combination of the two is what prevents roof leaks. Missing flashing or lack of regular maintenance to this flashing system are lead causes of roof leaks. Check that your chimney has proper flashing around it. A seal should be made between the chimney and the roof. If this is not the case, consult a manual to repair the flashing or call a professional.

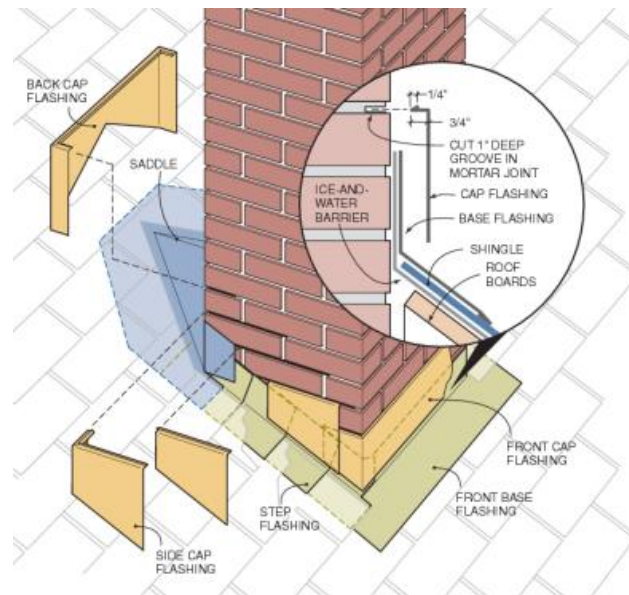

**LINER.** A chimney liner serves to prevent seepage of smoke into the house through little cracks in the chimney. The liner is generally made out of metal or ceramic. In older homes, the chimney may not have a liner or it may be damaged. Consult with a mason or a home maintenance manual for further information on repairs.



### ***DAMPER DOOR***

The damper is the metal door of sort that prevents energy loss through the chimney, when not being used. It also aids in the efficient removal of smoke from the fireplace and up the flu by preventing smoke from circulating backwards onto the smoke shelf and potentially back in the house. Occasionally these doors rust or are covered with creosote and do not operate properly. This compose a potential hazard if the door is not fully open while using the fireplace. Rust damage is also typical when a proper chimney cap is not installed. Older chimneys can be retrofitted with an external, spring loaded damper/chimney cap, as in the photo above.

***METAL CHIMNEYS.*** Some chimneys are made out of stainless steel rather than brick and mortar. They require a two inch clearance on all sides. Check for cracks and make sure that the pipes are secured tightly together. These chimneys generally need to be cleaned twice a year.

# EXTERIOR WALLS

Common materials used for exterior walls are listed below in Table 2. Regardless of its composition, exterior walls deserve a careful, semiannual inspection. Scan the surface of your home, using field glasses if necessary to check high places. Remember to look under the eaves, porches and other sheltered places. Look specifically for cracks, splits, peeling paint and any evidence of rot or insect damage. Walls can be maintained easily with regular check-ups and care. Many small repairs done regularly prevent larger repairs in the future. If you initiate any small repairs, we suggest that you visit your local library for a more detailed “how-to” help book. Finally, it’s a good practice to wash down your walls annually with a light detergent solution and rinse well.

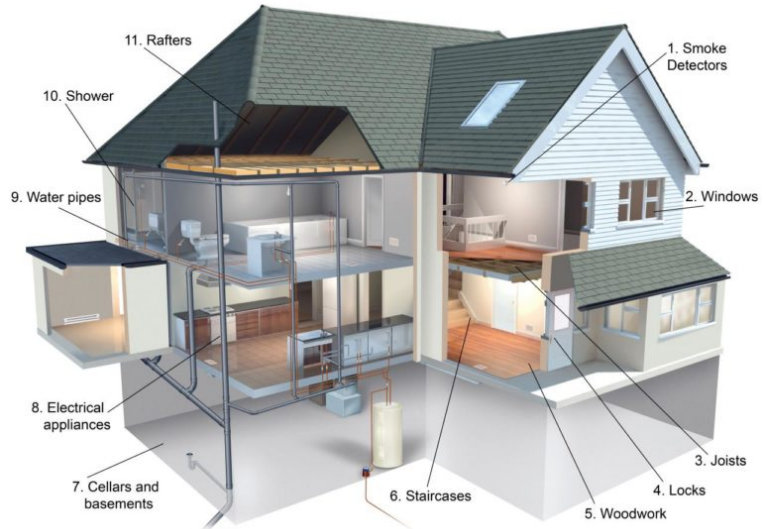

**Table 2: Common Materials for Exterior Walls**

Material	Maintenance	Life Span with Proper Maintenance
Manufactured Siding	Aluminum or steel siding may require painting.	Some brands offer life-time warranties.
Stucco	Check annually for cracks. Repair small cracks with a caulk appropriate for stucco. Larger cracks will require patching; consult a manual or a professional.	Indefinite.
Hardboard (Masonite)	Inspect caulk joints annually and check for peeling paint. Repair immediately because moisture causes hardboard to swell and deteriorate rapidly. Paint every 3-5 years.	20-25 years.
Vertical (Plywood)	Check caulk joints annually and repair as necessary. Stain every 3-5 years.	Indefinite.
Wood (Redwood or Cedar).	Check caulk joints and the condition of the paint annually. Touch up paint and re-caulk as necessary. Paint entire surface every 3-5 years.	Indefinite.

**Checklist for Exterior Walls:**

**MILDEW:** If you encounter dark, rash-like spots that won't wash off, suspect mildew. To remove mildew, scrub with a tri-sodium phosphate solution, or use a special mildew remover available at paint stores. If mildew has already damaged the paint, consult a manual or a professional.

**POPPED NAILS:** Look for popped nails or screws along the outside of the house. Make minor repairs as you go along. Choose screw-type or annular ring nails for better holding power, and drill pilot holes so you don't risk splitting the wood. Be sure to use rust-resistant galvanized or aluminum screws or nails; otherwise they'll eventually stain the paint around them.

**CAULKING:** Check for cracks, which allow air, water, and insects to enter your home. Use caulk wherever there are gaps, such as where siding meets the foundation or where flashing comes in contact with roofing. Caulking compounds differ in formulation and intended use. Before buying, read the product data to learn about surface preparation requirements, which materials the caulk will adhere to, and how long it must cure before you can paint over it.

**TERMITES AND CARPENTER ANTS:** Watch for evidence of devastating insects in early spring and fall. During these times, reproductive members of termite colonies sprout wings, take off on mating flights, discard the wings, and establish nesting places. If you find a pile of wings or mud trails along non-wood surfaces, suspect a colony nearby. If you find piles of sawdust, suspect carpenter ants. These ants live in wood anywhere in your house, especially where there are moisture problems. *Call a professional exterminator.*

**MASONRY WALLS:** Watch for cracks that might indicate settling.

**NOTE:** *Any major damage or deterioration of the exterior of your home should be looked at by a professional as soon as possible. Extended neglect of the exterior of your home will result in long term damage to the structure and interior systems of your home.*





# WINDOWS AND DOORS



Windows and doors need special maintenance because they have moveable parts and are exposed to the elements. They also frequently give homes a special character and can be expensive to replace. Therefore, proper maintenance is important. Exterior maintenance for doors and windows is discussed below; for suggestions about interior window maintenance, please refer to the next chapter of this manual.

## **Checklist for Windows and Doors:**

**CRACKED GLASS.** Few people make house calls to repair broken glass. If you cannot find a person to repair the glass you have three choices: 1) remove the sash and take it to a hardware store or glass shop for re-

glazing; 2) buy a new pane cut to size and install it yourself; or 3) cut the glass yourself from standard size sheets. A home maintenance book will manual you in exploring these options. Old glass has waves or imperfections in it, and is much more likely to shatter into shards than new glass. Take extra care when cleaning or caulking it.

**STORM WINDOWS.** Properly maintained and installed storm windows protect your home against heat loss. Check for cracked glass and a tight fit. Never caulk a storm window where it sits on the window sill because water can then collect on the sill causing it to rot.

**SCREENS.** Vacuum dirt from screening; and clean oxidized aluminum with car polish. Clean screens by blasting them with water from a hose, then scrubbing with a stiff brush. Don't forget the frame's edges. Also, mend any punctured screening with a dab of quick drying household cement. To patch metal screens, cut a section larger than the opening; unravel a few strands, fit over hole and bend strands back.

**WINDOW SILLS.** Check your window sills for deterioration or rot. The best prevention technique is paint. Sills should be inspected annually and repainted as necessary. Check for soft areas in the wood of the sill and brick mold by pressing a screw driver into the wood; if the screw driver penetrates beyond the wood's surface, this is an indication of rot. If the rotten area is not too extensive, a wood filler may be used to repair it. If the rot is extensive, the sill may need to be replaced. You may need to consult a professional carpenter.

**CAULKING.** Caulk around windows and follow the other advice included in the “Buttoning Up Your Home” section of the Energy Saver Chapter of this manual.

**STORM DOORS.** Binding or sticking doors may be caused by loose hinges or warped wood. Tighten hinges. Try rubbing soap or wax on areas that bind. If this doesn’t work, you may need to sand or plane down the door; consult a maintenance manual.

# PORCHES, DECKS AND PATIOS

Most porches and decks are wooden structures. The pores in wood absorb moisture, which encourages the growth of insects and fungi that destroy wood. Ultraviolet rays of the sun rob wood of its color and natural oils, causing cracking and splitting which then allows moisture to enter. Therefore, proper maintenance is essential to preserve the life of your porch or deck.



**PORCHES.** Check your porch for settling, damaged decking, roof leaks, and damage to porch steps and railings. A small problem may be easily repaired, but a problem ignored soon becomes a job for a professional. Immediate repair or replacement of damaged wood will mitigate further rotting of your porch.

**DECKS.** Posts, beams, and joists are particularly prone to rot because they're often near ground level and covered by decking. Steps and railings work loose through normal use, and finishes, no matter how tough, give way to weather. Rotting or mildew must be dealt with immediately because they cause the deck's condition to decline rapidly. Stains are the best sealants for a deck, so use them wherever possible. Be sure to ask for one formulated for exterior use. If your deck has been painted before, you'll have to settle for a fresh coat of paint after a thorough scraping. Use screws, not nails, to repair a deck as they prevent splitting of the wood and will not work loose over time.

**PATIOS.** Check your patio each spring. As the ground thaws, it may cause your patio to heave and crack. It will need to be replaced if severe heaving or cracking occurs. For information about caring for concrete, please refer to the paragraph about paving in the following section.

# WALKS, STEPS AND DRIVES

If you ignore a paving problem, it will usually get worse. When caught early enough, problems require only a modest expenditure of time and money. Look for *cracked, chipped, sunken, or heaved* steps or pavement. It pays to keep an eye out for problems and attend to them right away.

## Checklist for Walks, Steps and Drives:

**PAVING.** If you find a problem in the paving, try to locate the source. Frost, settlement, de-icing compounds, and tree roots all take their toll on even the best-laid paving.

**Asphalt** paving needs sealing every two years or whenever the surface becomes checked with hairline cracks or dries out.

**Concrete** paving should never be exposed to salt or calcium chloride products that are used to remove ice. It is common for concrete to crack. Minor cracks are to be expected. Larger cracks or heaving may indicate that the concrete needs to be replaced.

**Loose-fill drives** consist of gravel, pebbles, crushed rock, cinders, and slag. Although these drives are impervious to freezing and thawing, repeated use and erosion tend to deposit some of the fill onto your lawn or flush it down into the street, requiring that you replenish the material every few years.

**BRICK STEPS.** Moisture causes cracking in brick steps and makes the surface dangerously slick to walk on. Guard against moisture getting into the mortar joints by keeping your steps clear of ice and snow. Also, look for mortar damage in the treads, on the edges and in joints between the steps and the house or walk.

**WOODEN STEPS.** Check to make sure that wooden steps are shedding water, rather than soaking it in. Wooden steps are prone to the same moisture problems as porches and decks.

**NOTE:** *Never put salt or calcium chloride on concrete; it will cause the surface to crumble and flake off. To avoid this, use only a de-icer that is safe for concrete.*

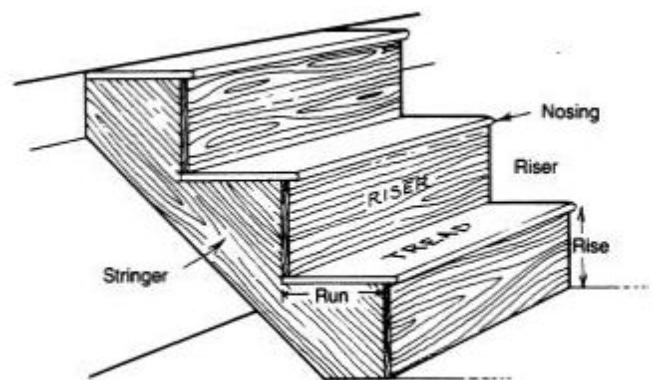

# GARAGES

Moisture plays a major role in garage door malfunctioning. It warps doors, rusts hardware, and causes framing to rot away. While looking for problems in your garage, check to make sure that water isn't building up around or dripping onto the door.

Keep door edges, panels, and bottoms sealed with paint. Repair any damaged concrete at the base of the door and replace any damaged hinges, lock sets, or tracks. Any non-functioning part can put additional strain on other components, causing future damage.

## **Checklist for Garages:**

**OVERHEAD GARAGE DOORS.** Any repairs to overhead garage doors should be done by a professional because serious injury can occur while attempting a repair.

**LOCKSETS.** The lock set is the device usually located in the middle of the door used to lock the garage door. Use graphite, not oil or grease, for lock sets because it is not affected by the cold and doesn't attract dirt. Puff the powder into the mechanism and into the key channel.

**PAINT OR SIDING.** Inspect for failing paint or rust on a metal door. Blackish marks near the base of a wood door is a sign of rot. Rust or bare metal is a sign of trouble for siding. You will need to paint to correct these problems; consult a manual or a professional.

**ROOF, WALLS AND WINDOWS.** Inspect in the same way as you do for the rest of your home.

**NOTE:** *The Building Code requires a one hour fire wall between an attached garage and the living area of a home.*

## Part 2: Inside the Home



# INTERIOR WALLS & CEILINGS

Interior walls should be inspected regularly for a variety of problems, such as cracks or evidence of moisture. Cracks indicate settlement or vibrations, and discoloration on the wall or ceiling may indicate a roof leak. If a wall appears to be crumbling, a roof leak should be suspected. If there is a bulge in a wall, assume that there is a humidity problem, a possible leak in the roof, or that your gutters aren't functioning properly. Popped nails may be due to the natural shrinkage and swelling that occurs in a house. Consult a professional.

A manual should be consulted on how to fill dents, mend split tape and set popped nails. If minor cracks or dents are ignored, they may escalate into larger jobs. An excellent way to inspect your walls in detail is to wash them regularly. Washing walls, especially in the kitchen and bathroom, also helps to control bacteria and odors.

**PAINTING.** In general, all repainting requires that the walls be washed before any paint is applied. It may be necessary to scrape loose paint, and any repairs of nail holes or dents should be sanded and primed before painting. Consult a paint store to determine: if there are lead-based paint hazards and the types of precautions you will need to take, the type of paint you will need, the right type of brush to use, the best way to use a roller, and how to clean brushes and rollers when you're done. By requesting information about painting from your paint or building supply store or by consulting a manual, materials and supplies won't be wasted needlessly, and you will follow the steps necessary to achieve long-lasting results.

# INTERIOR WINDOWS

The following table identifies the types of windows that are most common, as well as their maintenance needs.

**Table 3. Common Types of Windows**

Type	Description	Maintenance
Double-Hung	This window is actually two windows, each of which is called a sash. The upper-outside sash can be lowered and the lower-inside sash can be raised.	Problems may be due to a faulty spring lift or a broken sash cord. Consult a manual in order to properly dismantle the window and repair the fault.
Single-Hung	This window has a fixed upper pane and only the lower-inside sash can be opened (raised).	Problems and remedies same as above.
Awning	This window is hinged at the top and cranks open.	Keep the crank mechanism and weather-stripping clean.

Casement	Has hinges on the side like a door, is opened by using a crank.	Keep the crank mechanism and weather-stripping clean.
Louvered	Multiple horizontal panes hinged in tandem, is opened by using a crank. Primarily found on mobile homes.	Keep the crank mechanism and weather-stripping clean.
Slider	Window panes slide horizontally along a track.	Keep tracks clean.

Do not force a window open if it binds or refuses to budge because you will cause damage to the sash and/or frame. Inspect the window on both the inside and out. Paint may have sealed the window shut, or a stop molding may have warped. Usually these problems can be fixed by gently prying the window open. Regular cleaning of windows helps prevent future problems. A special tool for freeing a painted shut window can be purchased at a building supply store.

**INTERIOR MOISTURE PROBLEMS.** Water vapor may condense on windows or uninsulated walls, especially in the kitchen, bedrooms and bathrooms during the winter months. When there is lots of condensation, water runs down the window pane and onto the sill, which can lead to rotting of the sill. Use exhaust fans and storm windows to de-fog your windows. Check exterior walls for mold/mildew growth, especially in closets and other areas with limited air flow. Mop moisture from sills and keep sills well painted or finished to inhibit rot.

Bath fans, range hoods and clothes dryer vents must be exhausted to the outside. Often the exhaust ducts will disconnect and warm, moist air is discharged under the home, in the attic or garage, or back into the living space. This allows the growth of mold and rot. Exhaust ducts carrying warm moist air should be insulated if located in unconditioned space.

**DOUBLE (or TRIPLE) GLAZED WINDOWS.** Newer windows are usually double- or triple-glazed. These windows have two or three panes of glass with an air-lock in between the panes. If the integrity of the air-lock is lost, moisture will appear between the panes, and the window will need to be either replaced or repaired by a professional.





# FIREPLACES

A poorly maintained fireplace can be a safety hazard, allowing carbon monoxide or flames to enter your home. The fireplace can also be a source of heat loss; therefore, regular maintenance is important.

## Checklist for Fireplaces:

**FLUE.** Open the damper and peer up the flue. If you can't see light, check the flue with a mirror and flashlight to determine what the blockage is. The chimney flue should be cleaned periodically by a professional.

**DAMPER.** A damper has to seal tightly, or you will lose heat from your house through it. If yours won't close securely, feel around its edges and remove any small bits of mortar that may have lodged there. Also, ensure that the hinges and handle work smoothly so you can make necessary draft adjustments.

**FIREBOX.** For safety, most fireboxes are lined with high-temperature firebricks. Check to see if any have broken or have loose mortar. If so, consult a manual and repair.

**ASH PIT.** Usually the ash pit needs attention only every other year, depending on how frequently you use your fireplace. If the ashes seem soggy and hard to remove, suspect leakage. With clean-out doors that empty to the outside, seal gaps that might admit cold air. Use the removed ash in your compost pile or mix it into your garden.

# BASEMENTS AND FOUNDATIONS

If the floor or walls of your basement are chronically damp or wet, you have a moisture problem. If the floor of your basement has puddles, it is probably time to take action. Excessive moisture creates unusable space and could eventually undermine your home's footings and foundation walls.

**SOURCES OF BELOW-GROUND MOISTURE PROBLEMS.** Many moisture problems in your basement may require the help of a professional to solve. Moisture can be due to a variety of different factors:

**Condensation.** Condensation causes damp walls, pipes that drip, rusty hardware, and mildew. To identify condensation, tape a mirror in the dampest spot and wait 24 hours. If it's foggy or beaded with water, suspect condensation. Install a dehumidifier, improve ventilation, and/or seal interior walls.

**Seepage.** General dampness on the floor or on a particular wall, especially near floor level, may be caused by seepage. As before, tape a mirror to the wall. If moisture condenses behind it,

seepage is the culprit. Improve surface drainage in order to solve this problem. If you have a relatively minor problem with seepage, an interior sealer may work. If not, waterproof the foundation from the outside.

**Leaks.** Leaks are identified through localized wetness that seems to be oozing or even trickling from a foundation wall or floor. Check the damp area carefully, paying particular attention to mortar joints between blocks. Consult a professional about making the necessary repairs.

**Subterranean water.** A thin, barely noticeable film of water on the basement floor could be the first sign of a problem. Test by laying down vinyl or plastic sheets for two or three days; if moisture is penetrating, it will dampen the concrete underneath the vinyl sheet. Seek professional advice if this problem is discovered.

**LANDSCAPING.** Proper landscaping can help your basement resist moisture, especially when landscaping drains water away from the base of the house.

**GUTTERS.** Cleaning and properly positioning gutter extensions so that they drain away from the foundation will help keep moisture out of your basement and help extend the life of your foundation.

**WINDOW WELLS.** Water and debris can get trapped in window wells. Adequate drainage of these areas should be pursued. If your window well has a tendency to collect water, install a cover. These can be purchased at your local hardware or building supply store.

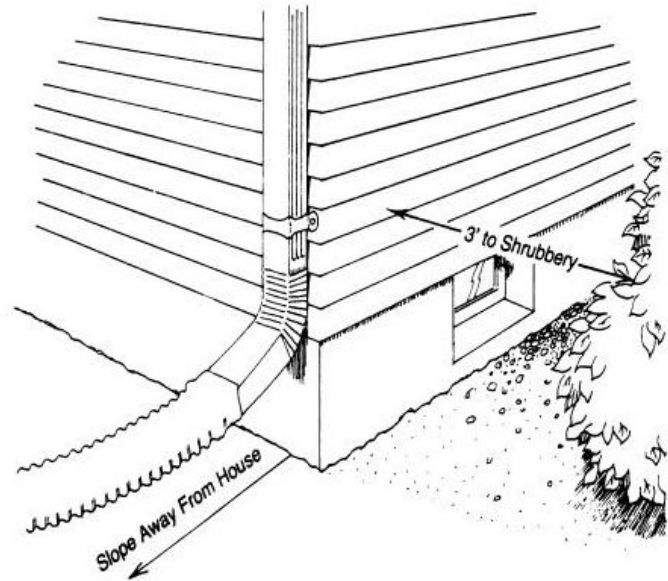

# Part 3: Major Systems

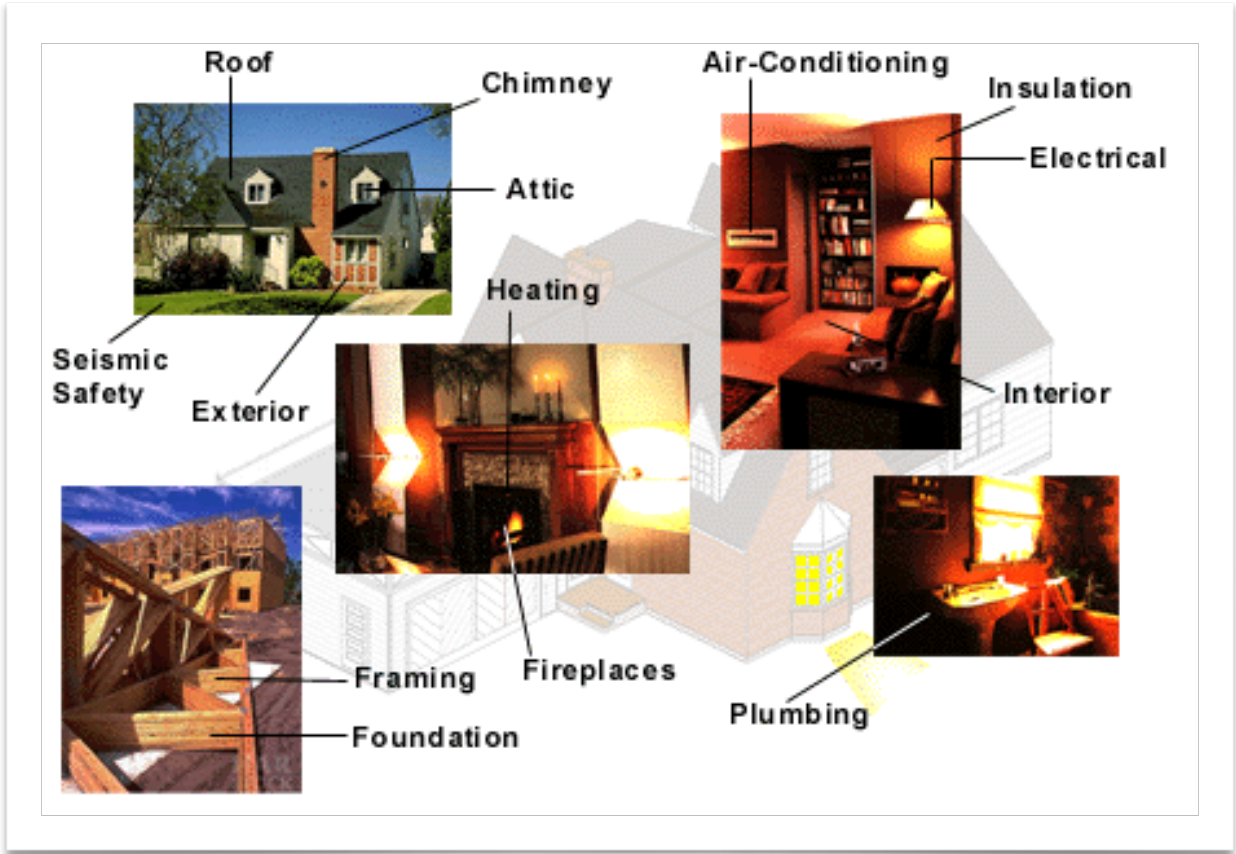

# HEATING SYSTEMS

There are many types of heating systems: forced air, piped hot water or steam, wood burning stove, electric baseboard or gravity. All heating systems have the common purpose of establishing and maintaining a comfortable temperature and humidity level. Each system has unique characteristics which should be maintained by a professional at least once a year. However, there is simple maintenance that you can do, as described below, to improve the efficiency of your heating system.

## **Checklist for Heating Systems:**

**FORCED AIR SYSTEMS.** In forced air systems, the furnace heats air which is blown through air ducts and delivered to rooms through registers.

**Filters.** Forced air heating tends to stir up dust and dirt. Therefore the furnace has a filter which keeps the furnace and ducts clean and functioning efficiently. Check the filter monthly to ensure high efficiency and replace it if necessary.

**Proper Clearance.** The furnace pulls air into return air vents which it then heats. It's important not to block the supply registers or the return air vents. Keep furniture, drapes and carpet away from both the registers and air vents, and keep them clean.

**WOOD BURNING STOVE.** Wood burning stoves are made out of either cast iron or steel. Wood is burned inside the stove, radiating heat into the room and house. Wood burning stoves can be a significant fire hazard unless properly installed and maintained.

**Clearance.** Adequate clearance must be maintained between the stove and chimney to all combustible materials such as walls, ceilings, and floors. All wood burning stoves should carry a label from a certified testing laboratory which verifies the proper clearances.

**Fire Box.** Check the interior fire box for cracks or warping. Approximately every five years, the wall seams of cast iron fire boxes need to be re-caulked with furnace cement.

**Door Seals.** Every two years all the rope gaskets around the door seals need to be replaced to ensure that the stove has a tight seal.

**Chimney.** The chimney pipe which comes out of your wood stove requires an 18 inch clearance. Check the pipe for weakness by testing it with your fingers and check for cracks.

**Heat Shield.** Combustible walls should have a proper heat shield of a noncombustible material such as metal or brick. Combustible floors should be protected according to the manufacturers' recommendations and the protective covering should extend at least 16" beyond and 8" to each side of the fuel loading door.

**ELECTRIC BASEBOARD.** For general maintenance information about electric systems, refer to the section on electricity in this section.

**Baseboards.** Vacuum to remove dust or dirt. Take care not to bump to avoid denting.

**WALL SYSTEMS.** Recessed into the wall and equipped with a blower. Vacuum to remove dust or dirt.

**GRAVITY SYSTEMS.** Old octopus style furnaces are characteristic of gravity systems. Due to the age of this type of system, it should be inspected annually by a qualified professional. Because it is inefficient, you may want to consider replacing it.

**GAS "SPACE" HEATER.** Vacuum to remove dust or dirt, take care not to extinguish pilot light.

**NOTE:** *If your furnace or hot water heater vent into a brick chimney, make sure that the chimney has a proper liner or the chimney may fail.*

# COOLING SYSTEMS

The cooling unit of your air conditioner both absorbs heat and reduces humidity. Whether you have a window unit or central air, you should try to locate the condensing unit on the shady side of your house.

Keep your unit well maintained so that it operates efficiently. An efficient system will keep the air in your home fresh and clean and will help keep electric bills to a minimum. As needed, refer to the owner's manual for your unit.

## Checklist for Cooling Systems:

**CONDENSING UNIT CLEARANCE.** The condensing unit of an air conditioner, which is located outside the house, is where the job of making cool air takes place. Air must flow freely for the condensing unit to function properly. Don't allow branches or other objects to come within three feet of the unit. Turn off the power to the unit, and then vacuum or hose out any leaves or other debris that may accumulate. During winter months, it is important to cover the condensing unit with a canvas or plastic tarp to protect it from the weather.

**CONDENSATION DRAIN.** The condensation drain carries excess moisture away from the unit. Make sure that it's not plugged and that it is directed towards the floor drain.

**FURNACE FILTER.** Your central air system uses the same blower as your furnace. Therefore, it is just as important to clean and replace the filter during the summer as it is during the winter.

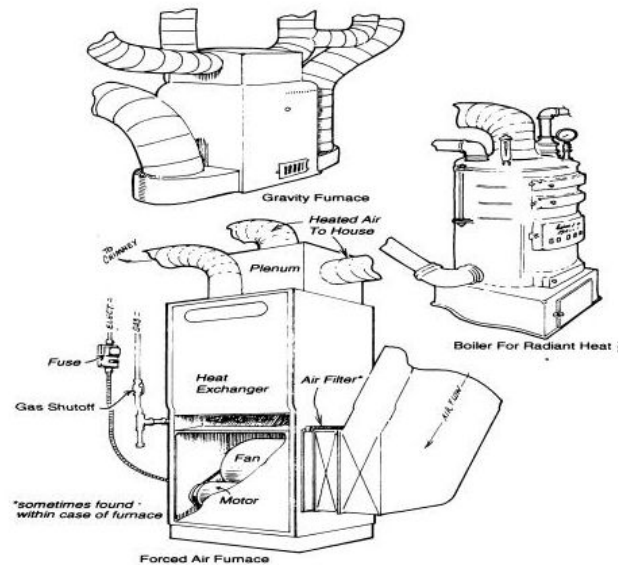

Different Types of Heating Systems

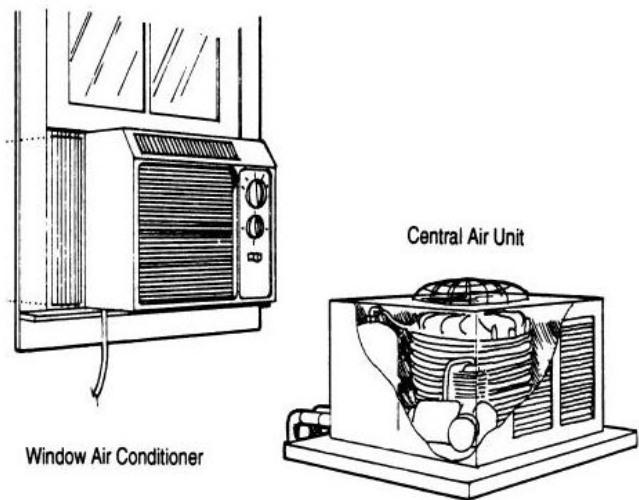

Different Types of Cooling Systems

# Six Easy HVAC Maintenance Tips



## **Inspect, Clean, or Change Air Filters Once a Month**

Change your filters often in your central air conditioner, furnace, and/or heat pump. Yes, even once a month during the heavy use months. A dirty filter can increase energy costs and damage your equipment, leading to early failure.

## **Schedule Seasonal HVAC Maintenance**

Have annual system maintenance service performed one to two months before the summer season begins. Research shows that keeping your system clean and running effectively can save you over 20% on your heating and cooling costs.

## **Clear the area around your HVAC system**

Keep the condensing unit free of debris. Trim shrubs and plants near your air conditioning unit to ensure proper airflow and circulation.

## **Clean Evaporator and Condenser Coils (once or twice a year)**

The U.S. Department of Energy says that “a dirty condenser coil can increase energy consumption by 30%. This video will show you how to wash your condenser unit in just a few minutes.

## **Maximize Air Flow**

Clean your vents and registers at least annually to help them circulate air as efficiently as possible. Consider duct cleaning as part of your annual maintenance service.

**Install a Programmable Thermostat**

Programmable thermostats can be programmed to change the temperature while you're away or sleeping and can cut an energy bill by at least 10%. It can also keep your system from overworking when not needed, and thereby prolonging its lifespan.



# PLUMBING

With your plumbing system, it is important to be always watching for leaks, and to fix them right away so that they don't get worse and cause water damage in your home.

When a pipe breaks or when you want to work on your plumbing, you will need to turn off the water supply. Water can be shut off just for a toilet or sink by turning off its own valve, usually located just under the toilet or sink. To shut off all the water in the house, turn off the main water valve. The main shut off valve could be located next to your water meter; it is important that you know where it is located so as to avoid major damage during a plumbing emergency.

## Checklist for Plumbing:

**CLOGGED DRAINS.** Grease, coffee grounds, hair and other substances can clog drains. It's best to try to keep these substances from entering the drain. For example, use a drain stopper and put grease in an empty tin can. A slow-acting drain is an indication of a partial blockage and should be cleared with a plunger before it becomes totally clogged. If your drain does completely clog, remove the drain stopper and clean out anything that may be blocking the pipe. If this doesn't work, try a plunger, plunging at least ten times, or try using a plumber's snake. You could also try a commercial drain cleaner, following the instructions carefully, or one of the degreasers mentioned in the section about cleaners in the Household Home-remedies Chapter.

**TOILET RUN-ON.** Take the top off the toilet's tank. If the water runs but the tank doesn't fill, check the rubber cone that covers the tank's drain. If it is soft or out of shape, it needs to be replaced. If the tank fills but the water still runs on, check to see if the float ball and its trip lever has risen or if the chain attached to the ball float is snagged. The float ball may have a leak and be filling with water; it will need to be replaced. The trip lever may be corroded or loose. It can be cleaned with steel wool or tightened with a screw driver.

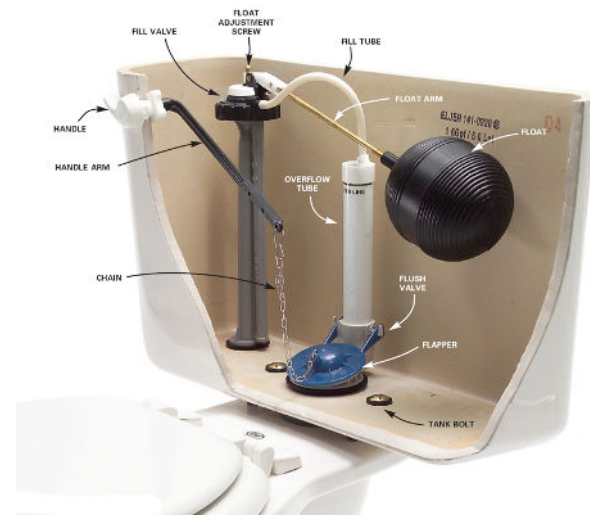

**FAUCETS.** Faucets leak for different reasons. If water leaks from around the stem of the faucet below the handle, the faucet may simply need to be tightened. Check for loose parts, then wrap a cloth around the packing nut to protect its finish and then tighten with a wrench. If this doesn't work, the internal parts of the faucet may need repair or replacement. Frequently, in old faucets the washer simply needs to be

replaced; in new faucets it's the cartridge that needs replacement. If water is not flowing freely from your faucet, try screwing off the strainer at the tip of the faucet and cleaning it. Consult a repair manual or call a plumber.

***SHOWERS AND TUBS.*** A major threat to walls and floors is moisture from your shower or tub. All joints which join the shower or tub to the walls and floor, such as the joint around the drain and those around tiles, need to be checked frequently and kept in good repair by caulking.

# WATER HEATERS

While the actual plumbing codes relating to water heaters are a bit more detailed, with many other requirements, below are the most typical safety deficiencies found during a home inspection.

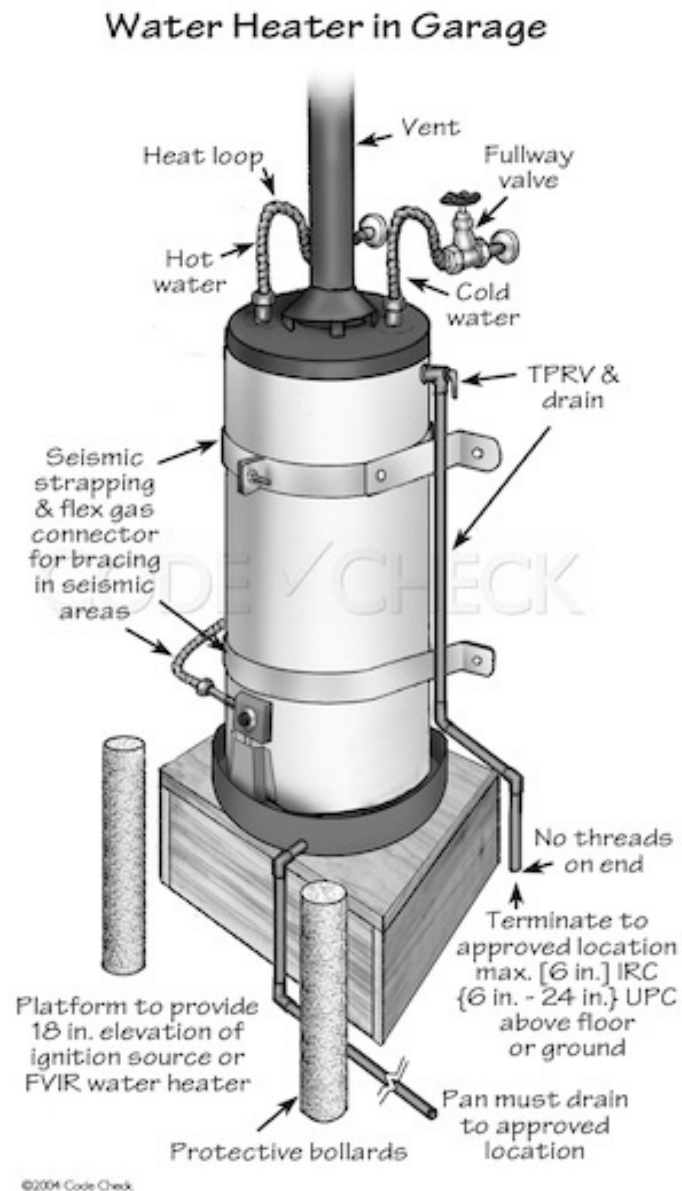

## **PROHIBITED LOCATIONS**

Generally, a water heater is not allowed to be installed inside a bedroom or sleeping area. There are some exceptions, but mostly for newer construction only. I've seen large laundry/utility rooms turned into bedrooms. The reason gas fire appliances are not allowed in bedrooms is due to the possibility of gas or carbon monoxide leaks.

## **GARAGE**

In a garage, a gas-fired water heater is required to be at least 18 inches off the ground and protected with a bollard (post). Fumes from gasoline or paint cans in a garage can cause an explosion if they are too close to the water heater.

## **STRAPPING**

Regardless of the location, water heaters are required to be strapped with 2 approved straps. One installed 1/3 of the way up and the other 1/3 of the way down the water heater. The lower strap has to be at least 4 inches away from the controls. Excessive movement of the water heater during an earthquake can cause the gas line to rupture.

## **GAS LINE**

The flexible gas connector is never allowed to protrude through any surface, like a wall, or a floor, or as in the case of the photo below, a sheet metal enclosure. In the event of an earthquake, the shaking would cause the gas line to be ruptured and the potential of an explosion is possible. The gas shut off valve is also required to be accessible for emergency shut off. Many times during my home inspections I see the gas shut off valve installed behind the water heater.



Unsafe Installation of Water Heater Gas Line

## COMBUSTION AIR SUPPLY

The burners of a gas-fired water heater need a certain amount of oxygen to burn properly. The absence of adequate oxygen can cause improper combustion and the production of carbon monoxide. This is especially important if the water heater is located inside the house. Water heaters are required to have two sources (one upper and one lower) of combustion air, regardless of where it is installed.



## TEMPERATURE PRESSURE RELIEF VALVE

The TPR Valve on the side or top of a water heater is designed to open up and relieve pressure if the temperature of the water or the pressure of the tank gets too high. The absence of a TPRV can cause the water heater to burst or worse, explode. The photo below is of a water heater that exploded in the garage of a Phoenix, Arizona home. Also, because any water escaping from the TPRV, that water will likely be scolding hot. A discharge pipe is required to be installed, leading water to the outside of the house.

## VENTING

As a bi-product of heating the water for your house, gas-fired water heaters produce a number of combustion gases such as carbon monoxide. Improper installation of a ventilation flue pipe can cause a backdraft, a potentially hazardous condition. Backdrafting is dangerous because if a water heater does not vent properly, the combustion gases may "spill" at the water heater rather than up the flue pipe to the exterior. This is potentially hazardous if the water heater is located inside the house. A water heater ventilation pipe is required to have a draft hood and terminate a minimum of one foot above the roofline, with a minimum slope of 1/4 inch per foot of pipe.



# WATER HEATER MAINTENANCE



The average replacement cost of a tank-type water heater, including labor, is approximately \$1,200, so making sure you get the full lifespan of your water heater should be high on your priority list. Luckily, extending the life of your water heater tank is simple and will maintain your water heater's efficiency and safety in just a few minutes of basic maintenance once a year.

## TOOLS REQUIRED

- Bucket
- Water hose
- Plumbers tape
- Rags
- Slip joint pliers

## MATERIALS REQUIRED

- Pressure relief valve (if old one leaks)
- Replacement drain valve (if the old one leaks)
- Anode rod (see photo below)

Luckily, all three of the items are inexpensive and can be purchased at your local hardware store.

## WHAT IS THE LIFESPAN OF A WATER HEATER?

The average lifespan of a tank water heater is approximately 10-15 years. Because water heaters often work perfectly for many years without any care, they're easy to neglect. But a few minutes of water heater maintenance once a year pays off by extending the tank's life span and maintaining your water heater's efficiency and safety.

## TEMPERATURE, PRESSURE RELIEF VALVE



The TPR valve opens when the pressure in the tank or the temperature of the water exceeds the limit. It can prevent the tank from exploding. Start the maintenance process by testing the TPR valve. To test the valve, first, place a bucket under the discharge pipe that connects to the TPR valve. You may find the valve on the top or the side of the water tank. Proceed to the next step by shutting off the cold-water and gas supply to the heater.

Let some water out by lifting the tap. Let go of the valve after a minute. Observe the valve; if the water does not stop flowing, there is a fault in the valve. Replace the old valve after draining the tank and unscrewing the old valve. Be sure to reinstall the discharge pipe that attaches to the bottom of the valve. New plumbing codes require the discharge line to terminate outside the house, but this may not be possible if it was installed many years ago and in a tight location.

## SACRIFICIAL ANODE ROD

Another important element of water heater maintenance checking the "sacrificial anode" rod. The sacrificial anode is an essential component of your water heater. It's a long metal rod, made of magnesium or aluminum, which extends through the tank's interior. It attracts particles of iron, limestone, or other minerals present in the water through an electrochemical process and corrodes in place of the tank.



Let out a few gallons from the water tank by putting a hose to the drain valve at the bottom of the tank. Unscrew the anode rod by fitting one 1/16-inch socket on its hexagonal head which you may find on top of the heater or under the top plate of the heater. If it is thinner than half of an inch, or you see extracts of calcium on it, the rod needs replacement. To install a new rod, wrap the thread of the rod with Teflon tape. Make sure you tightly screw it back to its position.

### **TANK SEDIMENT**

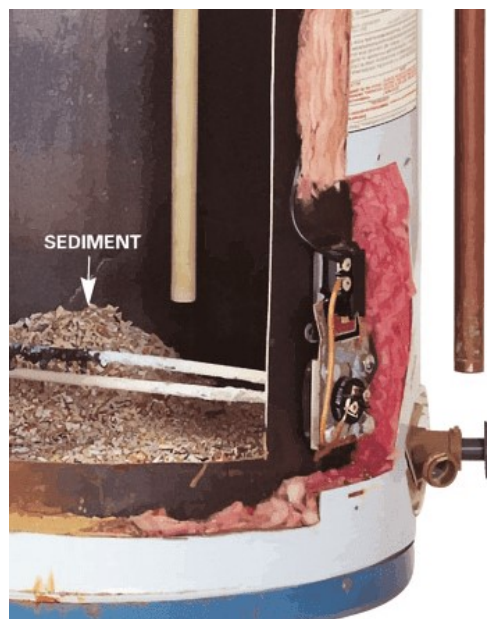

The tanks of water heater may contain sediment, which negatively impacts the performance of the heater. Drain the water from the tank and stir the sediment which is lying at the bottom of the tank. Do it while briefly opening the cold-water supply. Repeat the steps until clean and clear water comes out of the hose.



After you see clean water coming out of the tank's hose, close the drain cock. Make sure to turn the power off before you **start with this process of washing out the sediment.**

### **DRAINING THE TANK**

During the water heating process, naturally-occurring minerals like calcium and magnesium form into sediment particles that settle to the bottom of the tank. When sediment builds up, you'll start to experience issues like:

- Fluctuating water temperatures from too hot to lukewarm.
- Rising energy bills.
- A diminished supply of hot water.
- Rumbling or popping sounds when the water heater is running.

Drain the sediment by attaching a water hose to the drain valve, or by using a bucket. Open the drain valve slowly and let the water run until it's clear and free of sediments. Remember, the water will be hot!

Don't worry about any gurgling or groaning noises coming from the heater. That sound is just air entering the system as water drains out. If the drain valve won't close tightly when you're done, drain the tank completely, unscrew the old valve, and screw in a new one. To restart the water heater, open the shutoff valve and let the hot water run at any faucet to purge air from the system. Then turn on the power or relight the pilot.

Set your water heater's dial to 120 degrees F. If the dial doesn't have numbers, check the water temperature with a cooking thermometer. Higher temperatures increase sediment buildup and the risk of scalding injuries.

# ELECTRICAL

Maintaining your home's electrical system in good repair is vital for your safety. Although your home's electrical system can be complicated, you need to recognize its warning signs, such as: fuses or breakers that pop frequently, single marks around outlets, repetitive loss of power to a certain appliance, loose grip on electrical plugs, worn electrical cords. Ignoring warning signs can place you and your home in danger from fire. To be safe, use the following check list and contact a licensed electrician if you discover a problem.

## **Checklist for the Electrical System:**

***ELECTRICAL CORDS.*** Electrical extension cords should not be used on a permanent basis because they don't meet housing code requirements and can overheat. Electrical cords can become damaged and unsafe if they run under furniture or carpets, or if they have been attached to walls with staples or nails; these need to be replaced immediately. Damaged electrical cords, especially those that are frayed or cracked, may cause shock or fire. It is preferable to plug electrical appliances and devices directly into an outlet: have additional outlets installed by a licensed electrician or use a grounded outlet adapter (which is also called an outlet or power strip). Three-prong plugs include a grounding feature. *Never* remove the third prong for use in a 2-hole outlet. A temporary solution for 2-hole outlets is to use an adapter, but a better permanent solution is to have an electrician install a properly grounded outlet. Finally, keep cords out of the flow of traffic in your home because they may cause someone to trip.

***OUTLETS AND SWITCHES.*** All outlets and switches should have cover plates because exposed wiring presents a shock hazard. Warm or hot outlets, switches, or appliances which cause slight tingling when touched indicate unsafe wiring. Unplug cords and appliances, do not use switches, and contact an electrician as soon as possible.

***CIRCUIT BREAKERS/FUSES.*** If too many appliances are plugged into a single outlet, you may blow a fuse or breaker. A blown fuse or breaker tells you that something is wrong. Try plugging some appliances into a different outlet that's not on the same circuit. When you replace a fuse, be certain that correct size fuses are used because replacing with a larger size fuse is a fire danger.

## **GFCI OUTLETS**

**FACT:** Electrocution occurs when a small amount of electrical current (.1 to .2 Amps) flows through the heart for 1 to 3 seconds (less in small children).

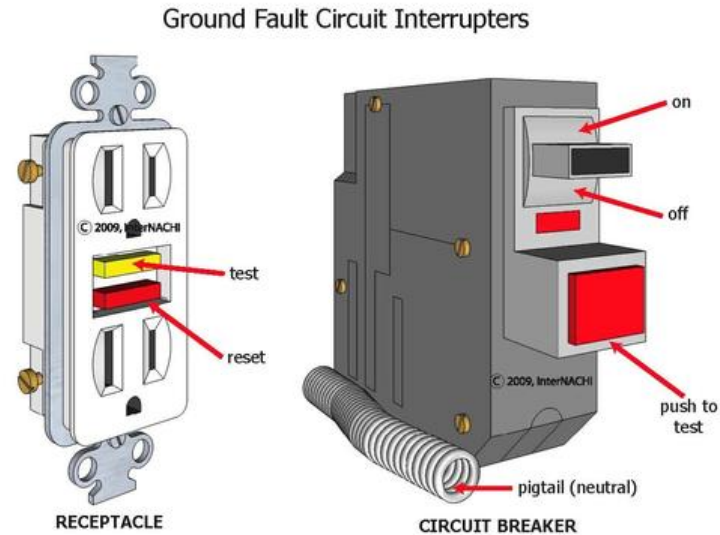

A ground fault circuit interrupter (GFCI) is an electrical device, either a receptacle or circuit breaker, which is designed to protect people from electric shock in a wet or damp environment. GFCI protection should not be confused with grounding. Even if a system is properly grounded, minor faults in a circuit can cause a dangerous shock to a person (especially children) using an appliance in a damp location or near water.

The GFCI senses the flow of electricity through a circuit. If more current is flowing through the black, or hot wire than the white or neutral wire, there is a current leakage (a "ground fault"). The GFCI can detect a leakage as little as five thousandths of an amp (.005 amps), which will shut off the current in 1/40 of a second to prevent injury.

### **WHERE GFCI PROTECTION IS REQUIRED**

- All bathroom receptacles
- All garages and accessory buildings
- All outdoor receptacles
- Crawlspace – at or below grade level
- Unfinished basements
- All kitchen countertop receptacles
- Laundry, utility & wet bar sinks within 6 feet of outer edge of sink
- Spa tub motors within 6 feet of tub

If you have GFCI's, it is recommended that you test (and reset) them monthly. On a GFCI receptacle when you push the TEST button, the RESET button should pop out, shutting off the circuit.

However, failure of the GFCI to trip in response to its own TEST button may or may not indicate a real defect. There may be an absence of ground, and the TEST button does nothing. The absence of ground has no effect on the operation of the GFCI. The device should work if there is a real short to ground. That is why a GFCI receptacle should be used in the areas listed above.

The same procedure should be done with a GFCI breaker. The GFCI will be located in the distribution or service panel. The breaker can be identified by a TEST button in addition to the breaker switch. Press the TEST button and the breaker switch should trip. Switch the breaker back to the ON position. Do this once a month – breakers have a tendency to stick, and may not protect you when needed.

GFCI receptacles should also be tested with a GFCI tester/analyzer for added assurance. Your home inspector can perform this test during the home inspection and will notify you if the GFCI outlets and breakers are present and in proper working order.

**PLEASE NOTE:** Building code requires GFCI outlets in the locations listed above for new construction. However, this may not have been the building requirement at the time some homes were built. If this is the case, it is still recommended that you upgrade your existing outlets in the above locations to GFCI. It can literally save your life or the life of a loved one! All electrical work should be performed by a licensed electrician.

## Part 4: Safety Around Your Home



# FIRE PREVENTION



Every year, October brings with it a very important and critical consideration: fire prevention. October is National Fire Prevention Month. Cooking equipment is the leading cause of home structure fires and home fire injuries. Smoking is the leading cause of civilian home fire deaths. Heating equipment is the second most common cause of home fire fatalities.

With that in mind, here are some tips to help you protect yourself and your family at home.

## **IN ALL AREAS OF THE HOME**

- There should be a smoke detector installed inside every bedroom and on every level of your home and in the hallways leading to the bedrooms.
- Smoke detectors should be tested on a regular basis and batteries replaced at least twice a year. Installing a 10-year battery smoke detector can make this easier.
- Teach children what smoke alarms sound like and what to do when they hear one.
- Ensure that all household members know two ways to escape from every room of your home and know the family meeting spot outside of your home.
- Practice escaping from your home at least twice a year. Press the smoke alarm test button or yell “Fire” to alert everyone that they must get out.
- Make sure everyone knows how to call 9-1-1.
- Teach household members to STOP, DROP and ROLL if their clothes should catch on fire.

- If a fire occurs in your home, GET OUT, STAY OUT and CALL FOR HELP. Never go back inside for anything or anyone.
- Have your heating system cleaned and inspected before winter operating it the cold months.

### **BASEMENT AND GARAGE**

- Keep paints, thinners, and other combustible chemicals away from gas water heaters. The fumes can cause an explosion and fire. Ideally, these materials should be kept in a locked metal cabinet, away from heat sources.
- Keep dirty rags in a sealed metal can or dispose of them.
- When not in actual use, lawnmowers and all gas-powered appliances should be stored empty.
- Keep electrical outlets covered and do not leave anything plugged in, when not in use.
- Store gasoline only in metal cans approved by your fire department.

### **KITCHEN**

- Turn pot handles in while using burners on the stove.
- Never leave food cooking unattended, especially deep fryers and other frying equipment.
- Make sure children are not near when working with hot liquids.
- Make sure electrical cords are not hanging over the counter and appliances are unplugged when not in use.
- Keep a fire extinguisher near the farthest exit from the stove.
- Do not use water to douse a flaming pot. Smother with cover or baking sheet or use a fire extinguisher.

### **BEDROOMS**

- In case of fire, it's a good practice to keep water in plastic bottles in bedroom closets to dampen cloths for face protection during an escape.
- Avoid using portable and fixed space heaters, as heating equipment is the second leading cause of home fire deaths.
- Even if you have smoke detectors in the hallways, you should sleep with the bedroom doors closed.
- Keep drapes away from heat sources, including lamps.
- Try to avoid the use of extension cords and overloading connectors. This can cause them to overheat and start a fire.

Research shows that more than half of homes destroyed during a wildfire were ignited by embers. The same holds true for urban fires. Embers can travel significantly from the main fire to land on roofs, gutters or decks or into the homes from other vents and openings. Here are some ways to combat embers and small flames that every homeowner can tackle easily to protect your home.





# SMOKE DETECTORS

The building code requires a smoke detector be installed in each bedroom, the adjacent hallway or room and on each floor level of your home, including the basement. A working smoke detector doubles your chance of surviving a fire, and it is therefore recommended that smoke detectors be installed in all bedrooms. Smoke detectors are powered either by batteries or by electricity. For both types it is important to open the smoke detector's cover once a year to remove dust and cobwebs which reduce sensitivity to smoke.

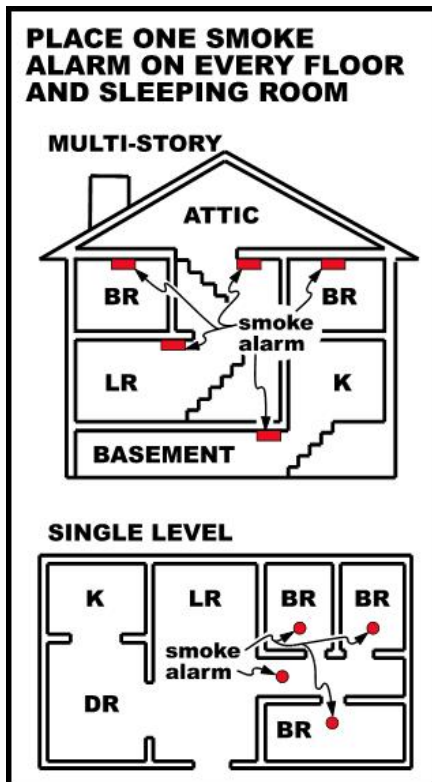

## Checklist for Smoke Detectors:

**BATTERY POWERED.** Determine if you have the old style smoke detectors which require new batteries at least twice a year. Many battery powered detectors will chirp or give some other audible sign when batteries need replacement. You should replace these smoke detectors with the new type powered by a ten-year battery. Battery powered smoke detectors are fine for existing housing, and can be purchased for less than \$20. Test smoke detectors regularly following the manufacturers instructions.

**ELECTRIC POWERED.** For new housing and remodeled housing, smoke detectors must be installed to operate on the household electric current with a battery backup. These smoke detectors may also chirp or give some audible sign when the battery backup needs replacement. The newer and safer electric smoke detectors contain a "hush feature" which allows you to silence the alarm for up to fifteen minutes, then automatically resets.

## FIRE EXTINGUISHER

Fire extinguishers are not required by code for owner-occupied homes, but they are highly recommended, especially close to your stove and furnace. Insurance companies will usually give homeowners a discount on their homeowners policy if the home has a fire extinguisher and smoke detectors. For fire extinguishers, a 5 lb. "2A:10BC" rating dry chemical extinguisher is recommended and can be purchased at a hardware or building supply store for approximately \$30.

## Checklist for Fire Extinguishers:

**MONTHLY INSPECTION.** Your fire extinguisher should be inspected monthly. Check the extinguisher's weight, the pressure gauge (the pointer should be in the operating range), and the tamper seal which

holds the ring-pin in place. Check also for damage or corrosion and for obstructions in the discharge hose and/or nozzle.

**RECHARGING.** Once the extinguisher has been used, even if just a little, it needs to be returned to an authorized service agency for recharging. Check the yellow pages of your phone book for companies that offer this service. They can also be consulted if you have questions about your monthly inspection results.

# CARBON MONOXIDE DETECTOR

Carbon monoxide is a colorless, odorless deadly gas which prevents the absorption of oxygen into the body. Carbon monoxide is also produced by common heat-producing household appliances which burn fossil fuels such as natural gas, oil, kerosene, and wood in furnaces, clothes dryers, water heaters, stoves or space heaters. Car fumes also contain carbon monoxide.

**CONTROL OF CARBON MONOXIDE.** To help control the production of carbon monoxide, make sure your fuel-burning appliances are properly installed and maintained. Also, never burn charcoal indoors or in the garage, and never leave your car running in the garage. Proper ventilation in the home is the best safeguard against carbon monoxide poisoning.

**DETECTION.** Carbon monoxide detectors, which look much like smoke detectors, are available. When purchasing a detector, check to make sure that it meets Underwriters Laboratory "UL 2034" requirements.

# LEAD-BASED PAINT

Lead poisoning may occur in children if they have been exposed to too much lead. Possible sources of lead poisoning include: eating lead-based paint chips, chewing on surfaces painted with lead-based paint, and playing in areas where the dust from lead-based paint is inhaled.

In the past, lead was used in paint to make it more durable. However, when lead poisoning was shown to cause brain damage and other illnesses, the use of lead-based paint began to be controlled. From 1960-1978 the amounts of lead used in paint were gradually reduced, and in 1978 lead in paint was banned for residential use.

- If your house was built prior to 1960, the chances of having lead-based paint somewhere in your house are almost 100%.
- If your home was built between 1960 and 1978, there is probably some lead-based paint.
- If your home was built after 1978, there should be no lead-based paint.

**DETECTION.** If your house was built prior to 1978, you should have painted surfaces tested before doing any scraping or sanding, especially if there is peeling or chipped paint. Scraping or sanding releases lead into the air and creates lead dust which will settle in carpets, food and clothes and does not dissolve. You may send paint samples to a Laboratory to test for the presence of lead.



# POOL SAFETY



## The Sad Facts

According to the Centers for Disease Control (CDC) drowning is the leading cause of death for children under the age of 14. Sadly, most or all of drownings are preventable.

## Childproofing

Although it seems obvious, close supervision of young children is vital for families with a residential pool. A common scenario is a young child leaving the house without the parent or caregiver realizing it. Children are drawn to water, and they can drown even if they know how to swim. All children should be supervised at all times while in and around a pool.

The key to preventing pool tragedies is to provide layers of protection. These layers include limiting pool access, using pool alarms, closely supervising children, and being prepared in case of an emergency. We suggest following these tips to prevent drowning:

- Fences and walls should be at least 4 feet high and installed completely around the pool. The fence should be no more than 2 inches above grade. Openings in the fence should be a maximum of 4 inches. A fence should be difficult to climb over.
- Fence gates should be self-closing and self-latching. The latch should be out of a small child's reach. The gate should open away from the pool; the latch should face the pool.

- Any doors with direct pool access should have an audible alarm that sounds for 30 seconds. The alarm control must be a minimum of 54 inches high and reset automatically.
- If the house forms one side of the barrier to the pool, then doors leading from the house to the pool should be protected with alarms that produce a sound when a door is opened.
- Young children who have taken swimming lessons should not be considered “drown proof”; young children should always be watched carefully while swimming.
- A power safety cover—a motor-powered barrier that can be placed over the water area—can be used when the pool is not in use.
- Rescue equipment and a telephone should be kept by the pool; emergency numbers should be posted. Knowing cardiopulmonary resuscitation (CPR) can be a lifesaver.
- For aboveground pools, steps and ladders should be secured and locked or removed when the pool is not in use.
- Babysitters should be instructed about potential hazards to young children in and around swimming pools and their need for constant supervision.
- If a child is missing, the pool should always be checked first. Seconds count in preventing death or disability.
- Pool alarms can be used as an added precaution. Underwater pool alarms can be used in conjunction with power safety covers. It’s also recommended that homeowners use remote alarm receivers so the alarm can be heard inside the house or in other places away from the pool area.
- Toys and flotation devices should be used in pools only under supervision; they should not be used in place of supervision.
- Well-maintained rescue equipment (including a ring buoy with an attached line and/or a shepherd’s crook rescue pole should be kept by the pool.
- All caregivers must know how to swim, know how to get emergency help, and know CPR.
- Children should be taught to swim (swimming classes are not recommended for children under the age of 4 years) and should always swim with a buddy.
- To prevent choking, chewing gum and eating should be avoided while swimming, diving, or playing in water.
- Water depth should be checked before entering a pool. The American Red Cross recommends 9 feet as a minimum depth for diving and jumping.
- Tables, chairs, and other objects should be placed well away from the pool fence to prevent children from using them to climb into the pool area.
- When the pool is not in use, all toys should be removed to prevent children from playing with or reaching for them and unintentionally falling into the water.
- A clear view of the pool from the house should be ensured by removing vegetation and other obstacles that block the view.

## **Hazards**

Numerous issues need to be considered before building residential pools: location of overhead power lines, installation and maintenance of ground fault circuit interruptors, electrical system grounding, electrical wiring sizing, location of the pool, and type of vegetation near the pool. The commonly used solar covers that rest on the surface of the pool and amplify sunlight do an excellent job of increasing the pool temperature, and they also increase the risk for drowning. If children or pets fall in and sink below the cover, it can be nearly impenetrable if they attempt to surface under it.

Winterizing the pool also can be hazardous. The pool water in most below ground pools is seldom drained because of groundwater pressure that can damage the structure of the pool. Therefore, water in most home pools is only lowered below the frost line for winter protection. In these cases, a pool cover is installed to keep debris and leaves from filling the pool in the winter months. The pool cover becomes an excellent mosquito-breeding area before the pool is reopened in the spring because of the decomposing vegetation that is on the pool cover, the rain that accumulates on the top of the pool cover during the winter, and the eggs laid on the pool cover in early fall and early spring. The cover also provides ideal conditions for mosquitoes to breed: stagnant water, protection from wind that can sink floating eggs, the near absence of predators, and warm water created by the pool cover collecting heat just below the surface

## **Home Inspections**

In California the new law, Senate Bill 442, also requires home inspectors to inspect pools and spas and report which safety features, if any, are present when a home is sold.

### **Safety features that comply with the new law, as outlined in Senate Bill 442:**

1. An enclosure that isolates the swimming pool or spa from the private single-family home.
2. Removable mesh fencing that meets American Society for Testing and Materials (ASTM) Specifications F2286 standards in conjunction with a gate that is self-closing and self-latching and can accommodate a key lockable device.
3. An approved safety pool cover
4. Exit alarms on the private single-family home's doors that provide direct access to the swimming pool or spa. The exit alarm may cause either an alarm noise or a verbal warning, such as a repeating notification that "the door to the pool is open."
5. A self-closing, self-latching device with a release mechanism placed no lower than 54 inches above the floor on the private single-family home's doors providing direct access to the swimming pool or spa.
6. An alarm that, when placed in a swimming pool or spa, will sound upon detection of accidental or unauthorized entrance into the water. The alarm shall meet and be independently certified to the ASTM

Standard F2208 “Standard Safety Specification for Residential Pool Alarms,” which includes surface motion, pressure, sonar, laser, and infrared type alarms. A swimming protection alarm feature designed for individual use, including an alarm attached to a child that sounds when the child exceeds a certain distance or becomes submerged in water, is not a qualifying drowning prevention safety feature.

7. Other means of protection, if the degree of protection afforded is equal to or greater than that afforded by any of the features set forth above and has been independently verified by an approved testing laboratory as meeting standards for those features established by the ASTM or the American Society of Mechanical Engineers (ASME).



# EARTHQUAKE SAFETY



We've all seen them, the video clips and the photos of devastation caused by earthquakes and natural disasters. Yet, ask yourself, are you really prepared? Without fail, every municipality I found in writing this article stated that they may, and very likely won't be able to get to you in an emergency after a quake or natural disaster. You and your family will very likely be on your own for at least 72 hours.

I personally experienced the wind storm here in Southern California in December of 2011 and was one of the city inspectors evaluating buildings after the storm. The devastation caused by wind alone crippled parts of the San Gabriel Valley for days and caused millions of dollars of damage, and in some cases tragedy.

## **10 THINGS YOU SHOULD KNOW ABOUT QUAKES**

1. After an earthquake, water mains may be broken leaving you without water for days. While not showering for a couple of days may be manageable, not being able to use your toilet won't be.
2. Power lines maybe downed, leaving you without power. This will leave you without the ability to use your heating and air conditioning, internet, and your refrigerator will shut off causing food to spoil.

3. Cell towers may be damaged, leaving you without the ability to communicate with family and loved ones.
4. Roads may be impassable due to downed trees and power lines or broken water mains. This might make it difficult to get home, pick up your kids from school or to check on loved ones.
5. Public transportation, like metro lines will likely not be working, while power is re-established and crews can inspect the tracks and tunnels.
6. Banks may be closed and ATM machines not working due to lack of power.
7. Stores might also be lacking power, leaving you without the ability to use debit or credit cards for food and supplies.
8. Gas stations will likely also be closed, as the pumps may not have power.
9. Your house or apartment may sustain damage and be deemed at least partially not livable.
10. First responders will be responding only to the most critical emergencies like fires and collapsed buildings.

If you're not prepared, please take heed and read on.

## **BEFORE THE QUAKE**

1. Make a plan! Discuss your plan with your family. Small children may be scared even discussing the plan, so be mindful of that and assure them everything will be okay.
2. Maintain emergency supplies and equipment at home in sturdy accessible containers. See below for a list of supplies.
3. Have a "go bag" (mobile survival kit) easily accessible or already in your car, with supplies, in case you need to leave your home in a hurry. See below.
4. Learn how to shut off gas, water, and electricity in case the lines are damaged. See the list below for a shut off wrench you should have near your meter.
5. Check chimneys and wall foundations for stability. If your home was built before 1935, check if your house is bolted to its foundation. If your home is on a raised foundation check if the cripple walls have been reinforced.
6. Secure your water heater and appliances that could move enough to rupture the gas lines and cause a fire or explosion.
7. Keep breakable and heavy objects on lower shelves, both in your kitchen and in your garage.
8. Put latches on cabinet doors to keep them closed during shaking. This will keep dishes and glasses from falling and shattering, causing a potential cut hazard.
9. Keep flammable or hazardous liquids such as paints, pest sprays or cleaning products in cabinets or secured on lower shelves.

## **DURING A QUAKE**

When you feel an earthquake, the first and most important thing you can do is to duck under a desk or sturdy table and cover your head, if at all possible. Objects may be moving and your furniture and dishes may be tossed around and break. Taking cover and making it past the original shaking is your first move.

Here are some additional tips for specific locations.

1. If you're at home, move away from heavy furniture which may fall over like bookshelves or dishes from kitchen cupboards. Take time NOW to anchor appliances and install security latches on cupboard doors to reduce hazards.
2. If you're in a high-rise building, and you are not near a desk or table, move against an interior wall, and protect your head with your arms. Do not use the elevators. Do not be surprised if the alarm or sprinkler systems come on.
3. If you're in bed, stay there until the quake stops. Pull your pillows over your head and hang tight. Then put on your shoes BEFORE you get out of bed.
4. If you're outdoors, move to a clear area, away from trees, buildings, or electrical wires and poles. Be very mindful of your surroundings as you move.
5. If you're on a sidewalk near buildings, duck into a doorway if possible, to protect yourself from falling bricks, glass, plaster, and other debris. Be mindful of fallen power lines.
6. If you're driving, pull over to the side of the road and stop. Avoid overpasses, power lines, and be mindful of other vehicles which may lose control. Stay inside the vehicle until the shaking is over.
7. If you're in a crowded store or public place, do not rush for exits. Rushing the exits tend to cause more injury than the earthquake itself.
8. If you're in a STADIUM OR THEATER, stay in your seat and protect your head with your arms. Do not try to leave until the shaking is over. Then leave in a calm, orderly manner. Avoid rushing toward exits.

## **AFTER THE QUAKE**

1. Remain calm and reassure others, especially small children and elderly people.
2. Check for injuries. Give first aid as necessary.
3. Check for fire. Take appropriate actions and precautions.
4. Check for gas leaks/smell. If you smell gas, shut off service at the meter. If gas is leaking, don't use matches, flashlights, appliances or electric switches. Open windows, leave building and report to gas company.
5. Avoid broken glass. Use gloves.
6. If you have a landline, replace all telephone receivers and use for emergency calls only.
7. Tune to the emergency broadcast station on radio or television. Listen for emergency bulletins.
8. Stay out of damaged buildings.

9. Be prepared for aftershocks, and plan where you will take cover when they occur.

## SUPPLIES AND EQUIPMENT AT HOME

1. First aid kit. A quality first aid kit is probably the most important item in your supply kit at home or on the go.



2. Gas and water shut off wrench. Take the time to learn where your meter is located and how to shut it off.



3. Work gloves. Very useful for clean up work.

4. Hammer/pry bar. Doors may not be openable after a quake.



5. Fire extinguisher (ABC-type). One for your home and one for your car.



6. Heavy Duty Broom for cleaning up debris.

7. Flashlight and extra batteries.

8. Hammer and nails. In case you need to board up broken windows.

9. Duct tape. One of the most versatile products ever invented.

10. Heavy duty plastic sheeting rolls (4 mil. 10' x 25'). Used for cleanup or covering broken windows.

11. Plastic garbage bags (heavy-duty, 30-gal. or larger)

12. Water filtration. Water even at home may not be drinkable.



13.4 Person Tent. This is extreme, and only if your home is deemed uninhabitable. You may have one already for camping trips.

## MOBILE SURVIVAL KIT

1. Nylon carrying bag or day-pack.



2. First aid kit



3. Multitool. This is a life saver!! It's gotten me out of several jams.



4. Duct Tape

5. Bottled water or portable water filter (see above).

6. Nonperishable food like protein or granola bars.

7. Portable radio/flashlight. Cell service may be out. Roads impassable. If you have to travel on foot, you will need a source of news.



8. Can opener. This may already be built in to your multi tool.

9. Flashlight and Extra Batteries

10. Gloves for clean up.

11. Essential medication (if refrigeration is not required)

12. Emergency sleeping bag/space blanket. These are extremely versatile in many conditions like heat or cold

13. Pre-moistened towelettes or baby wipes. Great for cleaning up your hands and face.

14. Walking shoes and extra socks. Be sure they are comfortable, incase your car is not accessible after a quake and you have to walk home.

15. Change of clothes. Comfortable clothes like jeans and t-shirts a good idea to keep in your pack or car.

# CHRISTMAS LIGHTS SAFETY TIPS

It's that time of year again. You've pulled out the Christmas lights from the garage, unraveled them, and getting ready to make your house visible from space, right? Wrong! Before you get started hanging lights on the house and stringing the tree, keep in mind that sadly, every year, without fail there are hundreds of accidents and fires reported. Most, if not all of these accidents can be avoided, by following some basic guidelines.

## 1. Inspect your lights

Before you break out the ladder to start installing the lights or stringing the Christmas tree, start by inspecting your existing lights. Unravel the lights and check the bulbs. Are there any broken, loose or damaged bulbs? If so, replace them. If the socket is damaged, it's time to replace the light string. Also, check the overall condition of the wiring and the plug. Again, you see any wear or damage, throw them out and get new lights. It's not worth the headache of having to replace them because they stopped working, after you've installed them on the house or tree.

## 2. Avoid retro C-9 incandescent lights

If you're like me, you might be a fan of the old-fashioned large, colorful, retro light bulbs. These lights are very reminiscent of my childhood. However, the bulbs are incandescent and get very hot, which is why they aren't recommended for your tree. Also, the glass bulbs break very easily, which means that you'll be climbing the ladder frequently (I remember my dad doing this) to replace bulbs.

You may ask "So what can I do?". The answer is simple. LED! LED lights look exactly the same! While a bit more expensive, they are a much safer option for indoor and outdoor lighting because they produce very little heat. They also last up to 25 times longer and use 75 percent less electricity.





### 3. Indoor and outdoor lights

Though indoor lights can be cheaper, don't use them as a substitute for outdoor lights. Indoor lights aren't as sealed against moisture as their outdoor counterparts, making them unsafe for wet winter weather. If you're not sure which type of lights you have, play it safe and check the label or toss them and buy new ones.



### 4. Only use three light strands per outlet

One of the craziest things I see throughout the year, but especially around the holidays, is too many things connected to one outlet, like the photo below. There is a limit to how many strands your can connect together and how many items your can plug on one outlet circuit. Be sure to read the labeling for installation restrictions. Typically you can only connect three consecutive strands. Just because the power strip has multiple outlets, doesn't mean you should load it up. Keep the number of items connected to one outlet as little as possible.

### 5. Hire a professional?

While decorating your tree is typically a family tradition, it's generally not a hazard if you follow the tips above. Outdoor lighting however can be a hazard if you aren't comfortable with heights and or the use of a ladder. Not to mention it's not as fun as decorating a tree while sipping on eggnog inside a warm house. Also, remember that you will have to take them down at the end of the holiday season.

You may want to consider hiring a Christmas light hanging service. Yes, believe it or not, there is such a service in most cities. They can hang the lights, take them down and repackage them for you and even put out the yard decorations too.

## 6. Use a timer

**The holidays are frequently a very hectic time of year.** Whether you're out gift shopping, attending holiday parties, or traveling, your Christmas lights shouldn't be anything you worry about. Putting your lights on timer will allow them to turn on, and more importantly off automatically.

Luckily, technology has evolved even with holiday decorating. There are a variety of products that make it easy to automate your lights. Timers and remote controls can turn your indoor and outdoor lights off with the touch of a button. With the advent of home automation, it's as easy as saying "Okay Google, turn on all Christmas light". Fun!



## 7. Extension cord safety

Most people don't realize that outdoor lights and extension cords can pose a safety risk. For example, when extension cords are on the ground (for ground decorations) pooling rain or melted snow can be a hazard. Keep the cords dry, and make sure to use surge protectors and GFCI outlets to minimize the danger.

## 8. Christmas tree fire hazards

Sadly, Christmas Trees are the leading cause of house fires during the holidays. While there are definitely benefits to a real tree, some people prefer artificial trees as safer choice. Most artificial trees are made with fire-resistant materials, making them fairly safe to light and decorate.

Personally, I always opt for a real tree. I love the smell. But doing so, I make sure it's fresh as possible when I buy it and always keep it well watered. Most people water it once and forget it. Once your tree dries out, it is no longer safe to keep the lights on and should be removed. When purchasing a tree, look for the freshest tree you can find and water it regularly to extend the life past the holidays.

That's it folks! I hope your holidays are filled with laughter, loved ones and lots of gifts. But above all, I hope you are safe and healthy. Follow the above tips to keep yourself and loves safe this holiday season.

# GENERAL HAZARDS IN THE HOME

For general safety around your home:

- make sure that all handrails are securely fastened and that your stairs are in good repair
- install grab bars and non-slip appliqués or non-skid mats in your bathtub or shower areas
- keep appliances away from water, especially if they're not plugged into a GFCI outlet
- don't overload outlets with extension cords or run electrical wiring under carpeting
- use extra caution when climbing ladders or standing on chairs
- keep fire sources, such as cigarettes, ash trays, heaters and hot pots, away from beds and paper products
- take special precautions with flammable substances such as gasoline and furniture polish; keep these far from the furnace and water heater, and immediately wash any rags containing these substances.
- make sure that lint from the clothes dryer does not accumulate and become a fire hazard, particularly in the dryer exhaust duct and around the washer & dryer motors.

## RADON

Radon, a radioactive gas, can seep into your home from the surrounding soil and then get trapped inside. Radon can also enter your home through well water in small amounts. Your risk of developing cancer from radon exposure depends on the average annual level of radon in your home. Radon is found all over the U.S. and can get into any type of building. Nearly one out of every 15 homes in the U.S. is estimated to have elevated radon levels.

**TEST FOR RADON.** Although radon is invisible and odorless, it is easy and inexpensive to detect. Radon detection kits, complete with instructions, are available at your local hardware store. If your home has a high radon level, it can be fixed, but first it must be detected. If you have questions about radon in your home, contact a professional inspector.



# ASBESTOS

## **What Is Asbestos?**

Asbestos is a mineral fiber that can be positively identified only with a special type of microscope. There are several types of asbestos fibers. In the past, asbestos was added to a variety of products to strengthen them and to provide heat insulation and fire resistance.

## **How Can Asbestos Affect Human Health?**

From studies of people who were exposed to asbestos in factories and shipyards, we know that breathing high levels of asbestos fibers can lead to an increased risk of lung cancer in the forms of mesothelioma, which is a cancer of the lining of the chest and the abdominal cavity, and asbestosis, in which the lungs become scarred with fibrous tissue.

The risk of lung cancer and mesothelioma increase with the number of fibers inhaled. The risk of lung cancer from inhaling asbestos fibers is also greater if you smoke. People who get asbestosis have usually been exposed to high levels of asbestos for a long time. The symptoms of these diseases do not usually appear until about 20 to 30 years after the first exposure to asbestos.

Most people exposed to small amounts of asbestos, as we all are in our daily lives, do not develop these health problems. However, if disturbed, asbestos material may release asbestos fibers, which can be inhaled into the lungs. The fibers can remain there for a long time, increasing the risk of disease. Asbestos material that would crumble easily if handled, or that has been sawed, scraped, or sanded into a powder, is more likely to create a health hazard.

### **Where Would Asbestos Be Found, and When Can it Be a Problem?**

Most products made today do not contain asbestos. Those few products made which still contain asbestos that could be inhaled are required to be labeled as such. However, until the 1970s, many types of building products and insulation materials used in homes contained asbestos. Common products that might have contained asbestos in the past, and conditions that may release fibers, include:

- steam pipes, boilers, and furnace ducts insulated with an asbestos blanket or asbestos paper tape. These materials may release asbestos fibers if damaged, repaired, or removed improperly;
- resilient floor tiles (vinyl asbestos, asphalt, and rubber), the backing on vinyl sheet flooring, and adhesives used for installing floor tile. Sanding tiles can release fibers, and so may scraping or sanding the backing of sheet flooring during removal;
- cement sheet, millboard, and paper used as insulation around furnaces and wood-burning stoves. Repairing or removing appliances may release asbestos fibers, and so may cutting, tearing, sanding, drilling, or sawing insulation;
- door gaskets in furnaces, wood stoves, and coal stoves. Worn seals can release asbestos fibers during use;
- soundproofing or decorative material sprayed on walls and ceilings. Loose, crumbly, or water-damaged material may release fibers, and so will sanding, drilling, or scraping the material;
- patching and joint compounds for walls and ceilings, and textured paints. Sanding, scraping, or drilling these surfaces may release asbestos fibers;
- asbestos cement roofing, shingles, and siding. These products are not likely to release asbestos fibers unless sawed, drilled, or cut;
- artificial ashes and embers sold for use in gas-fired fireplaces, and other older household products, such as fireproof gloves, stove-top pads, ironing board covers, and certain hairdryers; and
- automobile brake pads and linings, clutch facings, and gaskets.

### **Where Asbestos Hazards May Be Found in a Home?**

- Some roofing and siding shingles are made of asbestos cement.
- Houses built between 1930 and 1950 may have asbestos as insulation.
- Asbestos may be present in textured paint and in patching compounds used on wall and ceiling joints. Their use was banned in 1977.
- Artificial ashes and embers sold for use in gas-fired fireplaces may contain asbestos.
- Older products, such as stove-top pads, may have some asbestos compounds.
- Walls and floors around wood-burning stoves may be protected with asbestos paper, millboard, or cement sheets.
- Asbestos is found in some vinyl floor tiles and the backing on vinyl sheet flooring and adhesives.
- Hot water and steam pipes in older houses may be coated with an asbestos material or covered with an asbestos blanket or tape.
- Oil and coal furnaces and door gaskets may have asbestos insulation.

### **What Should Be Done About Asbestos in the Home?**

If you think asbestos may be in your home, don't panic. Usually, the best thing to do is to leave asbestos material that is in good condition alone. Generally, material in good condition will not release asbestos fibers. There is no danger unless the asbestos is disturbed and fibers are released and then inhaled into the lungs. Check material regularly if you suspect it may contain asbestos. Don't touch it, but look for signs of wear or damage, such as tears, abrasions, or water damage. Damaged material may release asbestos fibers. This is particularly true if you often disturb it by hitting, rubbing, or handling it, or if it is exposed to extreme vibration or airflow. Sometimes, the best way to deal with slightly damaged material is to limit access to the area and not touch or disturb it. Discard damaged or worn asbestos gloves, stove-top pads, and ironing board covers. Check with local health, environmental or other appropriate agencies to find out proper handling and disposal procedures. If asbestos material is more than slightly damaged, or if you are going to make changes in your home that might disturb it, repair or removal by a professional is needed. Before you have your house remodeled, find out whether asbestos materials are present.

### **How to Identify Materials That Contain Asbestos**

You can't tell whether a material contains asbestos simply by looking at it unless it is labeled. If in doubt, treat the material as if it contains asbestos, or have it sampled and analyzed by a qualified professional. A professional should take samples for analysis since a professional knows what to look for and because there may be an increased health risk if fibers are released. In fact, if done incorrectly, sampling can be more hazardous than leaving the material alone. Taking samples yourself is not recommended. If you nevertheless choose to take the samples yourself, take care not to release asbestos fibers into the air or onto yourself. Material that is in good condition and will not be disturbed (by remodeling, for example) should be left alone. Only material that is damaged or will be disturbed should be sampled. Anyone who samples asbestos-containing materials should have as much information as possible on the handling of asbestos before sampling and, at a minimum, should observe the following procedures:

- Make sure no one else is in the room when sampling is done.
- Wear disposable gloves or wash hands after sampling.
- Shut down any heating or cooling systems to minimize the spread of any released fibers.
- Do not disturb the material any more than is needed to take a small sample.
- Place a plastic sheet on the floor below the area to be sampled.
- Wet the material using a fine mist of water containing a few drops of detergent before taking the sample. The water/detergent mist will reduce the release of asbestos fibers.
- Carefully cut a piece from the entire depth of the material using a small knife, corer, or other sharp objects. Place the small piece into a clean container (a 35-mm film canister, small glass or plastic vial, or high-quality resealable plastic bag).
- Tightly seal the container after the sample is in it.
- Carefully dispose of the plastic sheet. Use a damp paper towel to clean up any material on the outside of the container or around the area sampled. Dispose of asbestos materials according to state and local procedures.

- Label the container with an identification number and clearly state when and where the sample was taken.
- Patch the sampled area with the smallest possible piece of duct tape to prevent fiber release.
- Send the sample to an asbestos analysis laboratory accredited by the National Voluntary Laboratory Accreditation Program (NVLAP) at the National Institute of Standards and Technology (NIST). Your state or local health department may also be able to help.

### **How to Manage an Asbestos Problem**

If the asbestos material is in good shape and will not be disturbed, do nothing! If it is a problem, there are two types of corrections: repair and removal. A repair usually involves either sealing or covering asbestos material. Sealing (encapsulation) involves treating the material with a sealant that either binds the asbestos fibers together or coats the material so that fibers are not released. Pipe, furnace, and boiler insulation can sometimes be repaired this way. This should be done only by a professional trained to handle asbestos safely. Covering (enclosure) involves placing something over or around the material that contains asbestos to prevent the release of fibers. Exposed insulated piping may be covered with a protective wrap or jacket. With any type of repair, asbestos remains in place. Repair is usually cheaper than removal, but it may make removal of asbestos later (if found to be necessary) more difficult and costly. Repairs can either be major or minor. Major repairs must be done only by a professional trained in methods for safely handling asbestos. Minor repairs should also be done by professionals since there is always a risk of exposure to fibers when asbestos is disturbed.

### **Repairs**

Doing minor repairs yourself is not recommended, since improper handling of asbestos materials can create a hazard where none existed. If you nevertheless choose to do minor repairs, you should have as much information as possible on the handling of asbestos before doing anything. Contact your state or local health department or regional EPA office for information about asbestos training programs in your area. Your local school district may also have information about asbestos professionals and training programs for school buildings. Even if you have completed a training program, do not try anything more than minor repairs. Before undertaking minor repairs, carefully examine the area around the damage to make sure it is stable. As a general rule, any damaged area which is bigger than the size of your hand is not considered a minor repair.

Before undertaking minor repairs, be sure to follow all the precautions described previously for sampling asbestos material. Always wet the asbestos material using a fine mist of water containing a few drops of detergent. Commercial products designed to fill holes and seal damaged areas are available. Small areas of material, such as pipe insulation, can be covered by wrapping a special fabric, such as re-wettable glass cloth, around it. These products are available from stores (listed in the telephone directory under "Safety Equipment and Clothing") that specialize in asbestos materials and safety items.

Removal is usually the most expensive method and, unless required by state or local regulations, should be the last option considered in most situations. This is because removal poses the greatest risk of fiber release. However, removal may be required when remodeling or making major changes to your home that will disturb asbestos material. Also, removal may be called for if asbestos material is damaged extensively and cannot be otherwise repaired. Removal is complex and must be done only by a contractor with special training. Improper removal may actually increase the health risks to you and your family.

### **Asbestos Professionals: Who Are They and What Can They Do?**

Asbestos professionals are trained in handling asbestos material. The type of professional will depend on the type of product and what needs to be done to correct the problem. You may hire a general asbestos contractor or, in some cases, a professional trained to handle specific products containing asbestos.

Asbestos professionals can conduct inspections, take samples of suspected material, assess its condition, and advise on the corrections that are needed, as well as who is qualified to make these corrections. Once again, material in good condition needs not to be sampled unless it is likely to be disturbed. Professional correction or abatement contractors repair and remove asbestos materials. Some firms offer combinations of testing, assessment, and correction. A professional hired to assess the need for corrective action should not be connected with an asbestos-correction firm. It is better to use two different firms so that there is no conflict of interest. Services vary from one area to another around the country. The federal government offers training courses for asbestos professionals around the country. Some state and local governments also offer or require training or certification courses. Ask asbestos professionals to document their completion of federal or state-approved training. Each person performing work in your home should provide proof of training and licensing in asbestos work, such as completion of EPA-approved training. State and local health departments or EPA regional offices may have listings of licensed professionals in your area.

If you have a problem that requires the services of asbestos professionals, check their credentials carefully. Hire professionals who are trained, experienced, reputable, and accredited -- especially if accreditation is required by state or local laws. Before hiring a professional, ask for references from previous clients. Find out if they were satisfied. Ask whether the professional has handled similar situations. Get cost estimates from several professionals, as the charges for these services can vary.

Though private homes are usually not covered by the asbestos regulations that apply to schools and public buildings, professionals should still use procedures described in federal or state-approved training. Homeowners should be alert to the chance of misleading claims by asbestos consultants and contractors. There have been reports of firms incorrectly claiming that asbestos materials in homes must be replaced. In other cases, firms have encouraged unnecessary removal or performed it improperly. Unnecessary removal is a waste of money. Improper removal may actually increase the health risks to you and your family. To guard against this, know what services are available and what procedures and precautions are needed to do the job properly.



In addition to general asbestos contractors, you may select a roofing, flooring, or plumbing contractor trained to handle asbestos when it is necessary to remove and replace roofing, flooring, siding, or asbestos-cement pipe that is part of a water system. Normally, roofing and flooring contractors are exempt from state and local licensing requirements because they do not perform any other asbestos correction work.

Asbestos-containing automobile brake pads and linings, clutch facings, and gaskets should be repaired and replaced only by a professional using special protective equipment. Many of these products are now available without asbestos.

**If you hire a corrective-action contractor:**

- Check with your local air pollution control board, the local agency responsible for worker safety, and the Better Business Bureau. Ask if the firm has had any safety violations. Find out if there are legal actions filed against it.
- Insist that the contractor uses the proper equipment to do the job. The workers must wear approved respirators, gloves, and other protective clothing.
- Before work begins, get a written contract specifying the work plan, cleanup, and the applicable federal, state, and local regulations which the contractor must follow (such as notification requirements and asbestos disposal procedures). Contact your state and local health departments, EPA regional office, and the Occupational Safety and Health Administration's regional office to find out what the regulations are. Be sure the contractor follows local asbestos removal and disposal laws. At the end of the job, get written assurance from the contractor that all procedures have been followed.
- Assure that the contractor avoids spreading or tracking asbestos dust into other areas of your home. They should seal off the work area from the rest of the house using plastic sheeting and duct tape, and also turn off the heating and air conditioning system. For some repairs, such as pipe insulation removal, plastic bags may be adequate. They must be sealed with tape and properly disposed of when the job is complete.
- Make sure the work site is clearly marked as a hazardous area. Do not allow household members or pets into the area until work is completed.
- Insist that the contractor apply a wetting agent to the asbestos material with a hand sprayer that creates a fine mist before removal. Wet fibers do not float in the air as easily as dry fibers and will be easier to clean up.
- Make sure the contractor does not break removed material into smaller pieces. This could release asbestos fibers into the air. Pipe insulation was usually installed in pre-formed blocks and should be removed in complete pieces.
- Upon completion, assure that the contractor cleans the area well with wet mops, wet rags, sponges, and/or HEPA (high-efficiency particulate air) vacuum cleaners. A regular vacuum cleaner must never be used. Wetting helps reduce the chance of spreading asbestos fibers in the air. All asbestos materials and disposable equipment and clothing used in the job must be placed in

sealed, leakproof, and labeled plastic bags. The work site should be visually free of dust and debris. Air monitoring (to make sure there is no increase of asbestos fibers in the air) may be necessary to assure that the contractor's job is done properly. This should be done by someone not connected with the contractor.

**Caution!**

Do not dust, sweep, or vacuum debris that may contain asbestos. These actions will disturb tiny asbestos fibers and may release them into the air. Remove dust by wet-mopping or with a special HEPA vacuum cleaner used by trained asbestos contractors.

# INDOOR AIR QUALITY



Indoor air quality is generally worse than most people believe, but there are things you can do about it.

## **Some Quick Facts:**

Indoor air quality can be worse than that of outdoor air.

- Problems can arise from moisture, insects, pets, appliances, radon, materials used in household products and furnishings, smoke, and other sources.
- Effects range from minor annoyances to major health risks.
- Remedies include ventilation, cleaning, moisture control, inspections, and following manufacturers' directions when using appliances and products.

Research has shown that the quality of indoor air can be worse than that of outdoor air. Many homes are built or remodeled more tightly, without regard to the factors that assure fresh and healthy indoor air. Our homes today contain many furnishings, appliances, and products that can affect indoor air quality.

## **Signs of indoor air quality problems include:**

- unusual and noticeable odors;
- stale or stuffy air;
- a noticeable lack of air movement;
- dirty or faulty central heating or air-conditioning equipment;
- damaged flue pipes and chimneys;
- unvented combustion air sources for fossil-fuel appliances;
- excessive humidity;
- the presence of molds and mildew;
- adverse health reaction after remodeling, weatherizing, bringing in new furniture, using household and hobby products, and moving into a new home; and
- feeling noticeably healthier outside.

### **Common Sources of Air Quality Problems**

Poor indoor air quality can arise from many sources. At least some of the following contaminants can be found in almost any home:

- moisture and biological pollutants, such as molds, mildew, dust mites, animal dander, and cockroaches;
- high humidity levels, inadequate ventilation, and poorly maintained humidifiers and air conditioners;
- combustion products, including carbon monoxide, from unvented fossil-fuel space heaters, unvented gas stoves and ovens, and back-drafting from furnaces and water heaters;
- formaldehyde from durable-press draperies and other textiles, particleboard products, such as cabinets and furniture framing, and adhesives;
- radon, which is a radioactive gas from the soil and rock beneath and around the home's foundation, groundwater wells, and some building materials;
- household products and furnishings, such as paints, solvents, air fresheners, hobby supplies, dry-cleaned clothing, aerosol sprays, adhesives, and fabric additives used in carpeting and furniture, which can release volatile organic compounds (VOC's);
- asbestos, which is found in most homes more than 20 years old. Sources include deteriorating, damaged, and disturbed pipe insulation, fire retardant, acoustical material (such as ceiling tiles), and floor tiles;
- lead from lead-based paint dust, which is created when removing paint by sanding, scraping, and burning;
- particulates from dust and pollen, fireplaces, wood stoves, kerosene heaters, and unvented gas space heaters; and
- tobacco smoke, which produces particulates, combustion products, and formaldehyde.

### **Amount of Ventilation**

If too little outdoor air enters a home, pollutants can accumulate to levels that can pose health and comfort problems. Unless they are built with a special mechanical means of ventilation, homes that are designed and constructed to minimize the amount of outdoor air that can "leak" into and out of the home

may have higher pollutant levels than other homes. However, because some weather conditions can drastically reduce the amount of outdoor air that enters a home, pollutants can build up even in homes that are normally considered "leaky."

### **How Does Outdoor Air Enter a House?**

Outdoor air enters and leaves a house by infiltration, natural ventilation, and mechanical ventilation. In a process known as infiltration, outdoor air flows into the house through openings, joints, and cracks in walls, floors, and ceilings, and around windows and doors. In natural ventilation, air moves through opened windows and doors. Air movement associated with infiltration and natural ventilation is caused by air-temperature differences between the indoors and outdoors, and by the wind. Finally, there are a number of mechanical ventilation devices, from outdoor-vented fans that intermittently remove air from a single room, such as the bathroom and kitchen, to air-handling systems that use fans and ductwork to continuously remove indoor air and distribute filtered and conditioned outdoor air to strategic points throughout the house. The rate at which outdoor air replaces indoor air is described as the air-exchange rate. When there is little infiltration, natural ventilation, or mechanical ventilation, the air-exchange rate is low and pollutant levels can increase.

### **Indoor Air Pollution and Health**

Health effects from indoor air pollutants may be experienced soon after exposure or, possibly years later.

#### **Immediate Effects**

Immediate effects may show up after a single exposure, or it may take repeated exposures. These include irritation of the eyes, nose, and throat, headaches, dizziness, and fatigue. Such immediate effects are usually short-term and treatable. Sometimes, the treatment is simply eliminating the person's exposure to the source of the pollution, if it can be identified. Symptoms of some diseases, including asthma, hypersensitivity pneumonitis, and humidifier fever, may also show up soon after exposure to some indoor air pollutants.

The likelihood of immediate reactions to indoor air pollutants depends on several factors. Age and pre-existing medical conditions are two important influences. In other cases, whether a person reacts to a pollutant depends on individual sensitivity, which varies tremendously from person to person. Some people can become sensitized to biological pollutants after repeated exposures, and it appears that some people can become sensitized to chemical pollutants, as well.

Certain immediate effects are similar to those from colds and other viral diseases, so it is often difficult to determine if the symptoms are a result of exposure to indoor air pollution. For this reason, it is important to pay attention to the time and place that symptoms occur. If the symptoms fade or go away when a person is away from home, for example, an effort should be made to identify indoor air sources that may be possible causes. Some effects may be made worse by an inadequate supply of outdoor air, or from the heating, cooling, or humidity conditions prevalent in the home.

**Long-Term Effects**

Other health effects may show up years after exposure has occurred, or only after long or repeated periods of exposure. These effects, which include some respiratory diseases, heart disease, and cancer, can be severely debilitating or fatal. It is prudent to try to improve the indoor air quality in your home even if symptoms are not noticeable.

While pollutants commonly found in indoor air are responsible for many harmful effects, there is considerable uncertainty about what concentrations or periods of exposure are necessary to produce specific health problems. People also react very differently to exposure to indoor air pollutants. Further research is needed to better understand which health effects occur after exposure to the average pollutant concentrations found in homes, and which occur from the higher concentrations over short periods of time.

## Part 5: Energy Saving Suggestions



*This chapter offers suggestions that you can implement in your home which will save energy, save money and help conserve natural resources. Using energy creates millions of carbon dioxide and other pollutants of the environment; the less energy we use, the more we preserve the environment and the more money we save.*

# WEATHERIZING YOUR HOME

In a climate like California, a household spends about 35% of their energy dollars on heat. A tight, well insulated house lowers your heating requirements, saves energy and money. Furthermore, you will be more comfortable in your home without the drafts common to homes that have not been weatherized.

## Checklist for Weatherizing Your Home:

**AIR LEAKS.** Air leakage can amount to as much as 40% of your heating bill. It also allows moisture into your home which may cause condensation in your insulation and eventually cause wood to rot. Air can leak out of and into your home through a wide variety of sources:

- Space around pipes
- Attic hatchway
- Space between chimney and roof
- Space between foundation and walls
- Fireplace damper
- Cracks or holes in foundations, walls, floors and ceilings
- Space around recessed lights, electrical outlets and switches
- Window, door and baseboard moldings
- Dropped ceilings above bathtubs and cabinets

These sources of leaks can be fixed. If the space to be filled is less than a quarter of an inch wide, use caulk. Foam sealant can be used for bigger spaces. For large openings, like attic hatches, use foam insulation.

**WINDOWS AND DOORS.** One-third of your home's heat loss occurs through windows and doors. Seal up windows with weather-stripping and/or caulk and fit with storm windows. You can also tape up a plastic film on the inside of your windows. If the window is in poor condition, you may want to consider replacing it with an energy efficient window. For doors, weather-strip around all edges and install door sweeps on the bottom. Weather-stripping should form a seal; replace any weather-stripping that is brittle, torn or cracked.





**INSULATION.** Insulating an uninsulated home may decrease heating energy use by 30-50%. However, some components are more cost effective than others. It is wise to evaluate the relative cost and benefit of each measure.

Relative Energy Savings  
from Insulating an Uninsulated Home

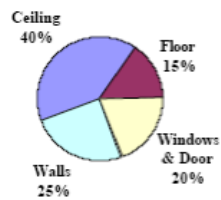

Relative Cost  
of Insulating an Uninsulated Home

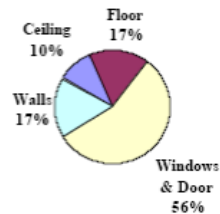

If you have to insulate a little bit at a time you'll realize the greatest benefit for your money by starting with the attic and floors. Insulating the walls is also very important because they cover the largest area in your home. You might consider hiring a contractor to blow insulation into your walls and ceiling. Make sure that the perimeter walls of your crawl space or the box sill of your basement are insulated.

## SYSTEMS

Energy conservation begins with systems that are maintained efficiently. If you need to replace your furnace, air conditioner, or any other appliance, be sure to consult an energy savings manual and compare the energy efficiencies for different units.

## HEATING

Heating is usually a household's single greatest energy expense. Performing the maintenance described in the Systems Chapter will help to save energy. Heating systems are also a major source of direct or indirect pollution, so it's best that they're efficient.

- **Thermostat.** At night, set the thermostat 10 degrees lower than you do during the day. When away from home for more than a day or two, set the thermostat to 55. Where possible, turn thermostats down in unused rooms.
- **Drapes and Blinds.** To help heat the house during the day, open drapes or blinds when the sun shines in, and close them at night to keep cold air out.
- **Pipe and Duct Insulation.** Pipes passing through unheated areas can be easily insulated with specially made foam or fiberglass insulation. For ducts, seal all joints and seams with duct tape

or mastic (a special paste) first. Then wrap any ducts that pass through unheated areas with insulation.

## **COOLING**

Degree for degree, cooling consumes much more energy than heating because of the nature of the cooling process which both absorbs heat and reduces humidity. There are many inexpensive alternatives to air conditioning.

- **Air Conditioners.** Electricity used by air conditioners consumes 5% of all electricity produced in the U.S. and costs homeowners billions of dollars. Use room units only in the room or rooms that you spend most of your time in, and close the doors to other rooms. Remember to turn off the air conditioner if you will be gone from home for more than a few hours, and remember to clean the filter. For maximum efficiency, keep the condensing unit in the shade. When purchasing a new unit, make sure to check the energy efficiency ratings and to buy the appropriate size for your room or home.
- **Fans.** Fans use much less electricity than air conditioners and are cheaper to run. Fans can be used to pull cool air from other parts of the house or from outside on cool nights. Ceiling fans draw up cool air from the floor and disperse hot air. Attic fans cool the house by pulling cool air through the windows and sending hot air out through attic vents; they cool best at night when the temperature drops.
- **Control Heat Gain.** Lights, windows and appliances are all sources of heat gain. To keep your home cooler during the summer: turn off lights when not needed and use lower wattage bulbs; insulate your walls and ceiling; close curtains against sunlight and consider planting trees or shrubs to provide shade to the east and west of your home; cook during the early morning and late evening, use the oven as little as possible and try drying your clothes outside in the sun. Try keeping the house closed up during the day to keep the heat out. Open windows in the evening when it is cooler outside.
- **Thermostat.** With air conditioning, set your thermostat at 78° F or higher. Using a ceiling fan will allow you to be just as comfortable as when the thermostat was set to a lower temperature.

## **PLUMBING/WATER HEATER**

Water heating is generally the second largest energy user in the home accounting for 20% of your electric bill. As with furnaces and air conditioners, when buying a new water heater, check the energy efficiency and buy the size that best fits your needs. Also compare costs for different fuel sources: electricity and natural gas.

# APPLIANCES



Over the years, appliances have become much more energy efficient. Check the age and condition of your major appliances. You may find that replacing an aging, inefficient appliance with a top-efficiency model is a good investment. When shopping for any new appliance, consult an energy manual for efficiency ratings and other important considerations.

## ***REFRIGERATOR***

**Location.** It's best to locate your refrigerator away from heat sources and out of direct sunlight. Try to keep it away from the dishwasher and oven.

**Temperature.** Use an accurate thermometer to check the temperature. The temperature in the refrigerator compartment should be between 36° F and 38° F, while the temperature in the freezer should be kept between 0° F and 5° F.

## **Energy Saving Tips.**

- To keep your refrigerator running as efficiently as possible, defrost regularly, clean the coils on the back or underneath the unit and make sure that the door seals tightly shut.
- Allow hot foods to cool before putting them in the refrigerator.
- Cover foods and liquids so that the humidity won't make the refrigerator work harder than normal.

- Keep the freezer nearly full with ice or frozen foods. If the refrigerator remains partly empty much of the time, fill it up with clean milk jugs—empty or full of water. This reduces the amount of cold air that escapes when the door is open.
- Defrost items in the refrigerator rather than on the counter.

### **STOVES AND OVENS**

**Safety.** With gas burners, make sure to install a ventilation fan to reduce the risks of carbon monoxide poisoning and gas leaks.

#### **Energy Saving Tips for Stoves and Ovens.**

In general, microwaves and crockpots use less energy than conventional ovens. However, for large quantities or several dishes, use a conventional oven.

- Use the smallest pan necessary - smaller pans require less energy.
- Copper bottom pans heat up faster than regular pans.
- Keep the stove top under the burners shiny so that heat is reflected rather than absorbed.
- With gas burners, make sure that the flame is blue, indicating that the gas is burning efficiently. A yellow flame indicates inefficiency.
- You may not need to pre-heat the oven at all unless you're cooking breads or pastries.
- Avoid peeking in because the temperature in your oven goes down 25° F every time you open the door.
- Self-clean the oven when it is already hot from a previous use.

## ***DISHWASHERS***

**Location.** Keep it away from your refrigerator.

### **Energy Saving Tips.**

- Try the “no heat” dry cycle, drying your dishes by fans rather than by an electric heating element, or simply open the dishwasher door and allow the dishes to air dry.
- If necessary, pre-rinse dishes using cold water.
- Use only when you have a full load of dishes - a half load and a full load use the same amount of energy.

## ***CLOTHES WASHER/DRYER***

**Location.** Washer and dryer will work more efficiently in a heated space. Also try to locate the washer as close to the water heater as possible to minimize heat loss through the pipes.

### **Energy Saving Tips for the Washer.**

- Always use the cold water rinse cycle; the temperature of the rinse water doesn't affect the cleaning capabilities of your washer.
- If clothes aren't greasy, try the warm or cold temperature settings for the wash cycle and the cold rinse cycle. This can save as much as 66 cents per load.
- Load your washing machine to capacity whenever possible, but don't overload it.
- Select the proper water level for the size of your load.
- Make sure the washing machine drain hose is not kinked and inhibiting the draining process, especially during the spin cycle. This causes clothes to be damper than normal and increases the drying time.

### **Energy Saving Tips for the Dryer.**

- Separate different types of clothes by weight and dry them separately to decrease drying time.
- Don't over dry clothes - this shortens fabric life and may cause shrinkage. Taking clothes out of the dryer while still slightly damp will reduce the need for ironing, which is another big energy user.
- Don't add wet clothes to a load that is already partially dried.
- Clean the dryer filter after each load - a clogged filter reduces dryer performance.
- When the weather is favorable, try using free solar energy and dry your clothes outside.

# LIGHTING

Lighting accounts for roughly 5-10% of the energy use in an average American home.

Energy Saving Tips.

- Turn the lights off, even if you're leaving the room for only a few minutes. With both florescent and incandescent lighting, turning the lights off even for only a few minutes will save energy.
- Use natural lighting whenever possible.
- Use compact fluorescents which save three-quarters of the electricity used by incandescents.
- With incandescent bulbs, it's generally safest and most efficient to use 60 watt bulbs.

If you have any questions about energy use in your home, contact the EREC (Energy Efficiency and Renewable Energy Clearinghouse, a public service office of the U.S. Department of Energy) at (800) 523-2929.

For further information, check the library. One good resource is *Eco-Renovation: The Ecological Improvement Manual* by Edward Harland.

Many of the suggestions offered in this section are traditional, time honored methods. We offer a variety of suggestions because there is no right answer when it comes to air fresheners, cleaning, or pest control; plus it's easiest for you if you can make use of what you already have sitting around your home.

**NOTE:** *Borax has long been recognized for its disinfectant and deodorizing properties; however, it is the most caustic of the cleaners in this chapter. Store it with special care, out of reach of children and away from other chemicals, and use it well diluted. Use latex gloves when working with Borax and dispose of it by pouring it slowly down the toilet.*

# AIR FRESHENERS

**Ventilation.** Open windows or doors in the house for at least a short period each day. This will help to reduce toxic fumes, odors and water vapor that may be building up indoors. Use the stove fan while cooking to reduce the concentration of fumes and odors in the area. Use the bathroom fan during and after a bath or shower.

**White Vinegar.** Distribute partially filled saucers of white vinegar around the room or boil 1 tablespoon of white vinegar in 1 cup of water to eliminate unpleasant cooking odors.

**Cinnamon and Cloves.** Boil these spices for fragrant smell. For ease of cleaning, boil in a cheesecloth bag.

**Potpourri.** Buy or make your own potpourri from your favorite flowers, herbs and spices. Place the potpourri in a small sachet bag.

**Vanilla.** Place pure vanilla on a cotton ball in a small saucer. Place the saucer in the car or refrigerator to remove odors. It is said to remove (or at least cover) even skunk odors. Keep the cotton ball out of the reach of children; vanilla has a high alcohol content.

**Baking Soda.** Place a partially filled saucer of baking soda on the refrigerator shelf. Replace every two months and when you do, pour the contents of the used box down the drains to remove odor and keep the drains clean. Baking soda can also be used to deodorize bottles by filling them with diluted baking soda and allowing the bottles to soak overnight, then wash as usual. Boxes of baking soda may also be placed near clothes and in the bathroom to absorb odor. Baking soda can also be used to deodorize carpets; make certain that the carpet is dry, sprinkle baking soda liberally over the entire carpet. Wait 15 minutes or overnight if the odor is particularly bad before vacuuming.

**Borax.** Empty the garbage frequently and clean the can as needed. To inhibit growth of odor-producing molds and bacteria, sprinkle 1/2 cup of Borax in the bottom of the garbage can.

**Borax and Cornmeal.** To neutralize carpet odors, sprinkle the carpet with a mixture of 1 cup Borax and 2 cups cornmeal. Let this mixture stand for 1 hour before vacuuming. Caution: do not use Borax in carpets or rugs where small children will be playing.

# CLEANERS

In general, white vinegar is the best of all alternative cleaners; however, it does not have disinfecting properties. Use it to clean everything from windows to greasy ovens. If grease is built up it may take detergent or ammonia to break it down.

## ***ALL-PURPOSE CLEANERS***

**White Vinegar and Salt.** Mix together for a good surface cleaner.

**Baking Soda.** Dissolve 4 tablespoons baking soda in one quart of warm water for a general cleaner, or use baking soda directly on a damp sponge. Baking soda will clean and deodorize all kitchen and bathroom surfaces.

**Liquid Soap and Borax.** Mix 1 quart warm water, 1 teaspoon liquid soap, 1 teaspoon borax, a squeeze of lemon or a splash of white vinegar. This solution can be used for a multitude of cleaning jobs including countertops, floors, walls, rugs and upholstery.

## ***CARPET PRE -TREATMENT***

*If you plan to shampoo your carpet, first try a pre-cleaning treatment.* Sweep the carpet, which will make the nap stand up and loosen the imbedded dirt, then vacuum. With this alone, the rug should show noticeable improvement, so much that you may decide to delay the shampooing.

## ***DISINFECTANT***

**Keep Things Dry.** Mold, mildew, and bacteria cannot live without moisture.

**Soap.** Regular cleaning with plain soap, or an antibacterial soap, and hot water will remove some bacteria.

**Borax.** Mix 1/2 cup Borax into 1 gallon hot water and clean with this solution. To inhibit mildew do not rinse off the borax solution.

**Isopropyl Alcohol.** This is an excellent disinfectant. Sponge and allow to dry (it must dry to do its job). Use in a well ventilated area and wear gloves. Caution: Don't use it in the kitchen around food.

## ***DRAIN CLEANERS AND OPENERS***



**Prevention.** To avoid clogging drains, use a drain strainer to trap food particles and hair; collect grease in cans rather than pouring it down the drain; pour a kettle of boiling water down the drain weekly to melt fat that may be building up in the drain, and put some white vinegar and baking soda down your drain weekly to break up fat and keep your drain smelling fresh.

**Plunger.** A time-honored drain opener is the plunger. This inexpensive tool will usually break up the clog and allow it to float away. It may take as many as ten plunges to unclog the drain.

**NOTE:** *Do not use this method after any commercial drain opener has been used or is still present in standing water.*

**Baking Soda and White Vinegar.** Pour 1/2 cup of baking soda down the drain. Add 1/2 cup of white vinegar and cover the drain if possible. Let sit for 15 minutes, then pour a kettle of boiling water down the drain to flush it. If you have a garbage disposal, pour in baking soda and then rinse with water.

**NOTE:** *Do not use this method after any commercial drain opener has been used or is still present in standing water.*

**Mechanical Snake (and a Garden Hose).** A flexible metal snake can be purchased or rented. It is threaded down the clogged drain and manually pushes the clog away. A garden hose turned on full power can then be used to flush the pipe clean.

## **FLOOR CLEANERS AND POLISHES**

### **For Vinyl Floors:**

**White Vinegar or Borax.** A few drops in the cleaning water will help remove grease particles. Dull, greasy film on no-wax linoleum can be washed away with 1/2 cup white vinegar or 1/4 cup borax mixed into 1/2 gallon to a full gallon of water. Your floor will look sparkling clean.

**Wax Remover (Club Soda).** Remove wax build up by pouring a small amount of club soda on a section. Scrub this in well. Let soak in a few minutes and wipe clean.

### **For Linoleum:**

**Mild Detergent, Baby Oil, Skim Milk.** Damp mop using a mild detergent and water for day to day cleaning. **Note,** following suggestions not for vinyl flooring. To preserve the linoleum floor you may wish to add a capful of baby oil to the mop water. Adding a small amount of sour or skim milk to rinse water will shine the floor without polishing.

**Wax Remover (Isopropyl Alcohol).** To remove old wax, mix a solution of 3 parts water to 1 part rubbing alcohol. Mop and scrub this in well and rinse thoroughly. Be sure the area is well ventilated and wear gloves.

**For Wood Floors:**

**Vegetable Oil and White Vinegar.** Mix a 1 to 1 ratio of oil and white vinegar into a solution and apply a thin coat. Rub in well.

**For Brick or Stone Floors:**

**White Vinegar.** Mix 1 cup white vinegar into a gallon of water. Scrub the floor with a brush using this solution and then rinse with clean water.

**For Ceramic Tile:**

**White Vinegar.** Mix 1/4 cup white vinegar (or more if very dirty) into 1 gallon water. This solution removes most dirt without scrubbing and does not leave a film. Washing ceramic tiles with soap does not work well in hard water areas because it leaves an insoluble film.

**Club Soda.** Polish your ceramic floor with club soda to make it sparkle.

**Sour or Skim Milk.** Rather than polishing, mix a small amount of sour or skim milk in the rinse water to make tile shine.

**Murphy's Oil Soap.** Use according to package directions.

**Special Problems:**

**Black Heel Marks.** Rub the heel mark with a paste of baking soda and water. Do not use too much water or the baking soda will lose its abrasive quality.

**Tar.** Scrape up excess tar with the side of a dull knife, then rub vigorously with butter or margarine. Rub again with your fingernail, a Popsicle stick, or anything that will not scratch the floor. Finally, wipe up the tar with a dry cloth.

**Crayon Marks.** Crayon marks on the floor can be removed by rubbing them with a damp cloth containing toothpaste. Toothpaste doesn't work well on wall paper or porous surfaces.

**Grease on Wood Floors.** If you spill grease on a wood floor, immediately place an ice cube or very cold water on the spot. The grease will harden and can then be scrapped off with a knife, then iron a piece of cloth over the grease spot.

**Grease Spots.** Immediately pour salt on the grease spot to absorb grease and prevent staining.

**Motor Oil.** Absorb spills on garage floor or driveway with cat litter, which is made of highly absorptive bentonite clay.

### ***LIME AND MINERAL DEPOSIT REMOVER***

**White Vinegar and Paper Towels.** Hard lime deposits around faucets can be softened for easy removal by covering the deposits with white vinegar-soaked paper towels. Leave the paper towels on for about an hour before cleaning. Leaves chrome clean and shiny.

**White Vinegar.** To remove deposits which may be clogging your metal shower head, combine ½ cup white vinegar and one quart of water in a cooking pot. Then completely submerge the shower head and boil for 15 minutes. If you have a plastic shower head, combine 1 pint white vinegar and 1 pint hot water. Completely submerge the shower head and soak for about one hour.

### ***OVEN CLEANERS***

**Salt.** While the oven is still warm, sprinkle salt on the spill. If the spill is completely dry, wet the spill lightly with water before sprinkling on salt. When the oven cools down, scrape away the spill and wash the area clean.

**Baking Soda or Borax and Steel Wool.** Sprinkle water then a layer of baking soda or borax. Wear rubber gloves and rub gently with a very fine steel wool pad for tough spots. Wipe off scum with dry paper towels or a sponge. Rinse well and wipe dry. For very baked-on spots, try scrubbing with pumice (available at hardware stores). As a last resort, use a pump oven cleaner that says it contains, "No caustic fumes" and "No Lye."

**Arm and Hammer Oven Cleaner.** Consumers Union chemists declared this product to be nontoxic. Use according to directions.

**Prevention:** Put a sheet of aluminum foil on the floor of the oven, underneath but not touching the heating element. Although this may slightly affect the browning of the food, the foil can be easily recycled when soiled. Clean up spills as soon as they occur. Retard grease buildup in your oven by dampening your cleaning rag in white vinegar and water before wiping out your oven.

## **TOILET BOWL CLEANER**

**Baking Soda and White Vinegar.** Sprinkle baking soda into the bowl, then drizzle with white vinegar and scour with a toilet brush. This combination both cleans and deodorizes.

***NOTE:** If you use bleach to clean your toilet bowl, never mix bleach with white vinegar, commercial toilet bowl cleaner, or ammonia. The combination of bleach with any of these substances suggested below produces a toxic gas which can be hazardous. Never mix lye with bleach because this will cause a small explosion.*

## **TUB AND TILE CLEANERS**

**Baking Soda.** Sprinkle baking soda like scouring powder. Rub with a damp sponge. Rinse thoroughly. To clean grout, put 3 cups baking soda into a bucket and add 1 cup warm water. Mix into a smooth paste and scrub into grout with a sponge or toothbrush. Rinse thoroughly.

**White Vinegar and Baking Soda.** To remove film buildup on bathtubs, apply full-strength white vinegar to a sponge and wipe. Next, use baking soda like scouring powder. Rub with a damp sponge and rinse thoroughly with clean water.

**White vinegar.** White vinegar removes most dirt without scrubbing and does not leave a film. Use 1/4 cup (or more) white vinegar to 1 gallon water.

## **WINDOW AND GLASS CLEANERS**

A few tips on window washing:

- Never wash windows while the sun is shining on them because they dry too quickly and leave streaks;
- When cleaning windows use up and down strokes on one side and side to side strokes on the other side. This will allow you to tell which side requires extra polishing;
- To clean windows or mirrors to a sparkling shine, try a natural linen towel, a clean damp chamois, a squeegee, or crumpled newspaper.

**White Vinegar.** Wash windows or glass with a mixture of equal parts of white vinegar and warm water, and dry with a soft cloth. Leaves windows and glass streak-less. To remove stubborn hard water spots and streaks use undiluted white vinegar.

**Borax.** Mix 2 tablespoons of borax into 3 cups water. Apply to surface and wipe dry.

**Toothpaste.** To lessen scratches, stains, or discoloration, rub a little toothpaste into the scratch. Polish with a soft cloth.

# PEST CONTROL

Helpful predators around the home include frogs, spiders, ladybugs, praying mantises, and dragonflies. Keeping these beneficial creatures around can help you reduce problematic pest populations.

## **ANTS:**

**Dish Detergent and Water.** Wash countertops, cabinets, and floor with equal parts liquid detergent and water to deter ant infestations. Store food in tightly sealed containers. If a line of ants is marching across the kitchen, find the point of entry and seal it. Use a silicone seal. Use petroleum jelly for a short-term fix until you have time to do a better job. Remove what the ants are eating and mop them up with soap and water.



**Flour and Borax.** Mix 1 cup flour and 2 cups borax in a quart jar. Punch holes in the jar lid. Sprinkle the contents around the house foundation. Keep borax out of the reach of children and pets.

## **FLEAS:**

**Vacuum.** Vacuum, remove the vacuum bag, seal it, and dispose of it immediately outside your home. Clean pet bedding at least weekly.

**Plants.** Spread leaves or shavings of Fennel, Rosemary, Red Cedar Shavings, Sassafras, Eucalyptus, or Pennyroyal under and around the pet's bed.

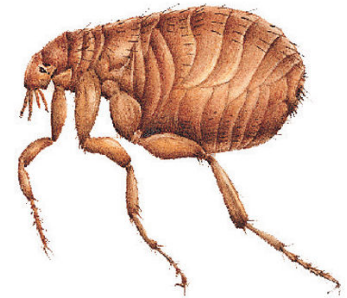

## **FLIES:**

**Prevention:** Keep kitchen garbage tightly closed. Dry soap or borax will act as a repellent if sprinkled into a garbage can that is clean and dry.



## **MOLES:**

**Castor Oil and Liquid Detergent.** Whip together 1 tablespoon castor oil and 2 tablespoons liquid detergent in a blender until the mixture is like shaving cream. Add 6 tablespoons water and whip again. **NOTE:** keep this mixture out of the reach of children and pets. Take a gradient sprinkling can and fill with warm water. Add 2 tablespoons of the oil mixture and stir. Sprinkle immediately over the areas of greatest mole infestation. For best results, apply after a rain or thorough watering.



## **MOSQUITOES:**

**Prevention:** Encourage natural predators such as dragon flies or praying mantises. Eliminate pools of stagnant water. Avoid wearing perfume, bright colors, flowery prints, and jewelry as these items attract mosquitoes. Try using citronella candles.



## **MOTHS:**

The moths you see aren't the ones to worry about. Moths that cause damage to clothes are too small to notice. The larvae of these moths eat fabric.



**Prevention:** Store clothing in a clean condition: moth larvae especially like areas soiled with food stains.

**Rosemary, Mint, Thyme, Cloves, Ginseng.** Half pound rosemary, 1/2 pound mint, 1/4 pound thyme, 1/4 pound ginseng (optional), and 2 tablespoons cloves. Mix and put in cheesecloth bags and place in closets or drawers (works best if clothes are clean and drawers seal tightly).

**Clothes Dryer.** Kill moths eggs by putting garment in a warm dryer for 5-10 minutes.

## **ROACHES:**



**Prevention:** Close off all gaps around pipes and electric lines where roaches enter the house by using cements or screening. Caulk small cracks along baseboards, walls, cupboards, and around pipes, sinks, and bathtub fixtures. Seal food tightly. Rinse food off dishes that are left overnight and clean off counter tops. Do not leave pet food out overnight. Take out the trash frequently.

**Hedge Apples.**(osage orange, *maclura pomifera*) Cut hedge apples in half and place several in the basement, around in cabinets, or under the house to repel roaches.

### **SLUGS AND SNAILS:**

**Natural Predators.** Garter snakes, grass snakes, ground beetles, box turtles, salamanders, and ducks all feed on snails.



**Beer.** Set out saucers or jars full of stale beer, placed below ground level near the garden. The fermented liquid draws them and they drown.



**Sourdough Starter.** Mix two cups warm water and two cups flour and add one packet baking yeast. Let work until clear liquid forms. Use as beer above.

### **WEEDS**

**Dandelions.** Spray with undiluted vinegar. Repeat if necessary.



## Part 6: All Seasons Maintenance Check Lists



	<b>Season</b>
<b>I. ROOFS &amp; GUTTERS:</b> To prevent roof leaks, condensation, and decay problems.	
a. Check for damaged, loose or missing shingles.	Spring & Fall
b. Check for leaking, rusted, misaligned or damaged gutters, downspouts, hangers, gutter guards and strainers.	Spring & Fall
c. Clean gutters, leaders, strainers, and drains. Be sure downspouts direct water away from foundation.	Periodically
d. Cut back tree limbs growing on or over roof.	Fall
e. Check antenna supports for sturdiness and possible source of leakage.	Annually
f. Check flashings around roof stacks, vents, skylights, chimneys for sources of leakage.	Spring & Fall
g. Check vents, louver and chimneys for birds nests, squirrels, insects.	Spring & Fall
h. Check fascias and soffits for paint flaking, leakage and decay.	Spring
<b>II. EXTERIOR WALLS:</b> To prevent paint failure, decay, and moisture penetration problems.	
a. Check painted surface for paint flaking or paint failure, including cracks, splits or peeling. Also check for mildew.	Spring
b. Check siding, shingles and trim for damage, looseness, warping, popped nails and decay. Wash each spring.	Periodically
c. Check exterior masonry walls for cracks, looseness, and broken or missing mortar.	Spring
d. Check for signs of insects, such as piles of termite wings or piles of sawdust.	Spring & Fall
e. Cut back and trim shrubbery against sidewalls	Spring & Fall
<b>III. DOORS &amp; WINDOWS:</b> To prevent air and weather penetration problems.	
a. Check caulking around doors, windows and window sills, corner boards, joints; re-caulk as needed. Also check for decay.	Fall
b. Check glazing putty around windows.	Fall
c. Check storm windows for cracked glass and a tight fit.	Fall
d. Check screens for rust, punctures or holes.	Spring
e. Check weather-stripping.	Fall
f. Check for failing paint on garage doors. Check for damaged concrete at the base of the door.	Spring

	Season
<b>IV. PORCHES, PATIOS &amp; DECKS:</b> To prevent moisture problems.	
a. Check your patio for heaving effects.	Spring
b. Check porches and decks to make sure that water beads after a rain	Periodically
c. Check porch and decks for rotting, settling, mildew, and damage to the stairs. Also check the porch roof for leaks.	Annually
<b>V. WALKS, DRIVES &amp; STEPS:</b> To prevent problems due to moisture and use.	
a. Check for cracked, chipped, sunken or heaved pavement or steps.	Periodically
b. Check for damage to mortar in brick steps.	Periodically
<b>VI. INTERIOR:</b> General house maintenance.	
a. Check bathroom tile joints, tub grouting and caulking. Be sure all tile joints in bathrooms are kept well sealed with tile grout to prevent damage to walls, floors and ceilings below.	Periodically
b. To prevent freezing, keep garage doors closed in winter.	Winter
c. Exposed water lines and drains should be wrapped with insulation.	Fall
d. Close crawl space vents in winter and open in summer. Open crawl space vents in summer and close in winter.	Spring & Fall
e. Check underside of roof for water stains, leaks, dampness and condensation, particularly in attics and around chimneys.	Annually
f. Check interior walls for cracks, bulges, popped nails or evidence of moisture.	Spring & Fall
g. Check to make sure that the damper of your fireplace seals tightly.	Fall
h. Check the firebox of your fireplace for broken or loose mortar. Also check the ash pit for signs of leakage.	Annually
i. To provide adequate ventilation, keep attic louvers and vents open all year round. Check louver screening.	Annually
j. Check for soft spots or sagging in floors and stairs.	Spring & Fall
<b>VII. INTERIOR: FOUNDATION &amp; MASONRY:</b> To prevent seepage and condensation.	
a. Check basement for dampness and leakage after wet weather.	Periodically
b. Check foundation walls, retaining walls, garage floors, etc., for cracks, heaving, moisture and crumbling.	Spring
c. Check chimneys for deteriorated chimney caps, hot spots, and loose or missing mortar.	Spring & Fall
d. Check to make sure that water is not collecting in window wells.	Spring
e. Maintain grading sloped away from foundation walls.	Annually

	<b>Season</b>
<b>XII. KNOW THE LOCATION OF:</b> For safety.	
a. The main water shut-off valve. This should be opened and closed at least once a year to assure proper functioning.	Annually
b. The main electrical disconnect or breaker.	---
c. The electrical panel box for breakers or fuses. Never overfuse.	---
d. All fire extinguishers in the house.	---
e. The main emergency shut-off switch for the heating system.	---
f. Carbon Monoxide detectors and smoke alarms. Change old style smoke detector batteries every 6 months (alarm will chirp intermittently if the battery has worn out). Better yet, install newer style detectors with 10-year batteries. Test any detectors on a regular basis.	Every 6 Months

# HOME CONSTRUCTION TERMINOLOGY

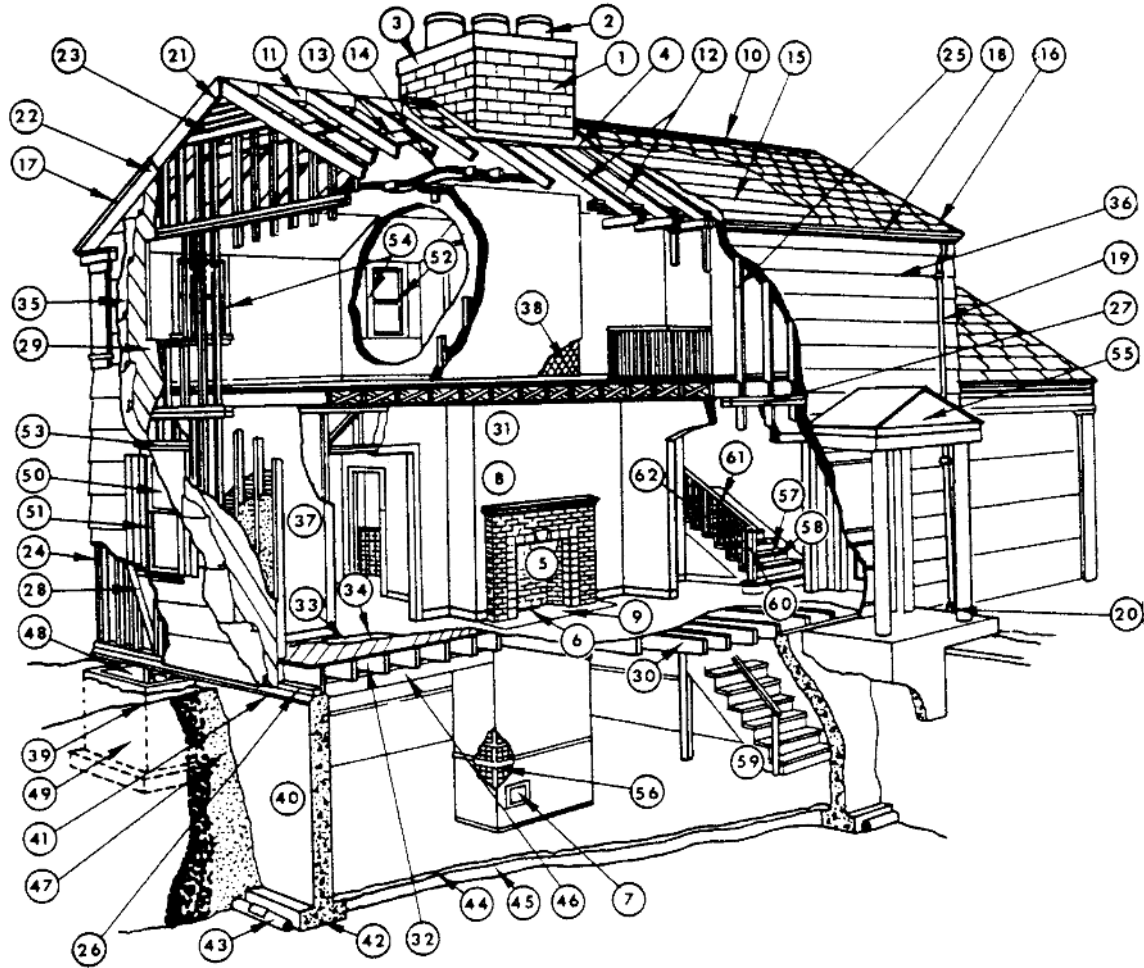

1. **Chimney** – A Vertical masonry shaft of reinforced concrete or other approved, noncombustible, heat resisting material enclosing one or more flues. It removes the products of combustion from solid to liquid or gaseous fuel.
2. **Flue Liner** – The flue is the hole in the chimney. The liner, usually of terra cotta, protects the brick from harmful smoke gases.
3. **Chimney Cap** – This top is generally of concrete. It protects the brick from weather.
4. **Chimney Flashing** – Sheet metal flashing provides a tight joint between chimney and roof.
5. **Firebrick** – An ordinary brick cannot withstand the heat of direct fire, so special firebrick is used to line the fireplace.
6. **Ash Dump** – A trap door to let the ashes drop to a pit below, where they may be easily removed.

7. **Clean-out Door** – The door to the ash pit or the bottom of a chimney through which the chimney can be cleaned.
8. **Chimney Breast** – The inside face of front of a fireplace chimney.
9. **Hearth** – The floor of a fireplace that extends into the room for safety purposes.
10. **Ridge** – The top intersection of two opposite adjoining roof surfaces.
11. **Ridge board** – The board that follows along under the ridge.
12. **Roof Rafters** – The structural members that support the roof.
13. **Collar Beam** – Really not a beam at all. A tie that keeps the roof from spreading. Connects similar rafters on opposite side of roof.
14. **Roof Insulation** – An insulating material (usually rock wool or fiberglass) in a blanket form placed between the roof rafters for the purpose of keeping a house warm in the winter, cool in the summer.
15. **Roof Sheathing** – The boards that provide the base for the finish roof.
16. **Roofing** – The wood, asphalt or asbestos shingles-or tile, slate or metal-that form the outer protection against the weather.
17. **Cornice** – A decorative element made up of molded members usually placed at or near the top of an exterior or interior wall.
18. **Gutter** – The trough that gathers rainwater from a roof.
19. **Downspout** – The pipe that leads the water down from the gutter.
20. **Storm Sewer Tile** – The underground pipe that receives the water from the downspouts and carries it to the sewer.
21. **Gable** – The triangular end of a building with a sloping roof.
22. **Barrage Board** – The fascia or board at the gable just under the edge of the roof.
23. **Louvers** – A series of slanted slots arranged to keep out rain, yet allow ventilation.
24. **Corner Post** – The vertical member at the corner of the frame, made up to receive inner and outer covering materials.
25. **Studs** – The vertical wood members of the house, usually 2 x 4", generally spaced every 16".
26. **Sill** – The board that is laid first on the foundation and on which the frame rests.
27. **Plate** – The board laid across the top ends of the studs to hold them even and rigid.
28. **Corner Bracing** – Diagonal strips to keep the frame square and plumb.
29. **Sheathing** – The first layer of outer wall covering nailed to the studs.
30. **Joist** – The structural member or beams that hold up the floor or ceiling, usually 2" x 10" or 2" x 12" spaced 16" apart.
31. **Bridging** – Cross bridging or solid. Members at the middle or third points of joist spans to brace one to the next and prevent their twisting.
32. **Sub-flooring** – The rough boards that are laid over the joist; usually laid diagonally.
33. **Flooring Paper** – A felt paper laid on the rough floor to stop air infiltration and, to some extent, noise.
34. **Finish Flooring** – Usually hardwood, of tongued and grooved strips.
35. **Building Paper** – Paper placed outside the sheathing, not as a vapor barrier, but to prevent water and air from leaking in. Building paper is also used as a tarred felt under shingles or siding to keep out moisture or wind.

36. **Beveled Siding** – Sometimes called clapboards, with a thick butt and a thin upper edge lapped to shed water.
37. **Wall Insulation** – A blanket of wool or reflective foil placed inside the walls.
38. **Metal Lath** – A mesh made from sheet metal into which plaster is applied.
39. **Finished Grade Line** – The top of the ground at the foundation.
40. **Foundation Wall** – The wall of poured concrete (shown) or concrete blocks that rest on the footing and supports the remainder of the house.
41. **Termite Shield** – A metal baffle to prevent termites from entering the frame.
42. **Footing** – The concrete pad that carries the entire weight of the house upon the earth.
43. **Footing Drain Tile** – A pipe with cracks at the joints to allow underground water to drain in and away before it gets into the basement.
44. **Basement Floor Slab** – The 4" or 5" layer of concrete that forms the basement floor.
45. **Gravel Fill** – Placed under the slab to allow drainage and to guard against a damp floor.
46. **Girder** – The main beam upon which floor joists rest. Usually of steel, but also of wood.
47. **Backfill** – Earth, once dug out, that has been replaced and tamped down around the foundation.
48. **Areaway** – An open space to allow light and air to a window. Also called a light well.
49. **Area Wall** – The wall of metal or concrete that forms the open area.
50. **Window** – An opening in a building for admitting light and air. It usually has a pane or panes of glass and is set in a frame or sash that is generally movable for opening and shutting.
51. **Window Frame** – The lining of the window opening.
52. **Window Sash** – The inner frame, usually movable, that holds the glass.
53. **Lintel** – The structural beam over a window or door opening.
54. **Window Casing** – The decorative strips surrounding a window opening on the inside.
55. **Entrance Canopy** – A roof extended over the entrance door.
56. **Furring** – Creating an air space with thin strips of wood or metal before adding boards or plaster.
57. **Stair Tread** – The horizontal strip where we put our foot when we climb up or down the stairs.
58. **Stair Riser** – The vertical board connecting one tread to the next.
59. **Stair Stringer** – The sloping board that supports the ends of the steps.
60. **Newel** – The post that terminates the railing.
61. **Stair Rail** – The bar used for a handhold when we use the stairs.
62. **Balusters** – Vertical rods or spindles supporting a rail.